

FILED FOR RECORD
IN MY OFFICE
AT 3:05 O'CLOCK P M

FEB 20 2014

CLARA JONES
COUNTY CLERK, PANOLA COUNTY, TEXAS
BY [Signature] DEPUTY

VOL. 87 PAGE 439

MEETING OF COMMISSIONERS' COURT OF PANOLA COUNTY

TO WHOM IT MAY CONCERN:

PURSUANT TO THE TEXAS OPEN MEETINGS ACT, NOTICE IS HEREBY GIVEN THAT A SPECIAL MEETING OF THE COMMISSIONERS' COURT OF PANOLA COUNTY, TEXAS WILL BE HELD ON THE 24TH DAY OF FEBRUARY, 2014, IN THE COMMISSIONERS' COURTROOM IN THE PANOLA COUNTY COURTHOUSE IN CARTHAGE, TEXAS AT 9 00 O'CLOCK A.M AT WHICH MEETING THE FOLLOWING SUBJECTS WILL BE DISCUSSED AND THE FOLLOWING MATTERS ACTED UPON.

OPENING PRAYER.

OPEN MEETING:

1. **CITIZEN COMMENTS:** This is for citizens to comment on any subject not on the current agenda concerning county business. Members of the Court may answer direct questions, but any action from this item must be scheduled on a future agenda.
2. **COMMISSIONERS' REPORT:** These are for informational purposes only. Any action that needs to be taken on the basis of these reports will be placed on a future agenda for action.
3. **COUNTY JUDGE'S REPORT:** This is for informational purposes only. Any action that needs to be taken on the basis of this report will be placed on a future agenda for action.
4. **CONSENT ITEMS:**

PERSONNEL

- a. To record an increase in salary to \$13.93 per hour for Amanda Walker Geddie, permanent part-time Deputy Clerk in the Panola County Auto Registration Office, effective February 24, 2014.
- b. To record the retirement of Linda Howard as Technical Services Coordinator with the Sammy Brown Library effective March 31, 2014.

- c. To record the retirement of Perry Pitts, an Operator with the Panola County Road and Bridge Department, Precinct #2, effective February 28, 2014

ROAD & BRIDGE

- a. To approve and record a request by Murvaul Gas Gathering, LLC to cross under Panola County Road #221 with a 12.75 inch line.
- b. To approve and record a request by Murvaul Gas Gathering, LLC to cross under Panola County Road #225 with a 12.75 inch line.
- c. To approve and record a request by Murvaul Gas Gathering, LLC to cross under Panola County Road #274 with a 12.75 inch line

MISCELLANEOUS

- a. To record Statement of Officer and Oath of Office forms for Panola County Deputy Constable, Precincts #2 and #3, Daniel McMillen.
- b. To approve and record 2014 Budget Amendment No. 5.
- c. To record Panola County Sheriff's State Forfeiture Amendment No. 1 for Fiscal Year 2014.

REQUESTS FOR CONFERENCE ATTENDANCE

- a. To approve and record a Request for Attendance at a Conference for the following Panola County elected official(s)/employee(s) Panola County Assistant Criminal District Attorney Katie Nielsen, PCSD Sgt Jeff Ivy, and PCSD Investigator James Ferris
- 5. To approve Road & Bridge requisitions and to approve payment of current Panola County bills as presented on vouchers prepared and submitted by the County Auditor.
 - 6. To open sealed bids for New Roof on Panola County Sheriff's Department Building Complex. Bid may be awarded at a future meeting of the Court
 - 7. To appoint Jim Stevens, Pastor Carl Anderson, Ms. Fatha Burchette, Reverend Steve Jackson, and Reverend Mervyn Scott to the Sexually Oriented Business Order, Permit and License Appeal Board for a one year term commencing February 27, 2014 and ending February 27, 2015
 - 8. To discuss and act upon approving an update to Panola County's TxCDBG Citizen Complaint Procedures as required by the Texas Community Development Block Grant Program.
 - 9. To discuss and act upon proclaiming April, 2014 as Fair Housing Month in Panola County.

- 10. To discuss and act upon approving a contract between East Texas Council of Governments and Panola County with regards to the Regional Evaluation Services for Juveniles.
- 11. To discuss and act upon declaring the following property as surplus property: one (1) 7 x 14 cattle guard; one (1) Delta 78 gallon L shaped fuel tank; one (1) Hyster Grid Packer/Roller; Miscellaneous tires and rims; six (6) sets of Caterpillar Cutting Edges; and one (1) Massey Ferguson 492 Clutch and Pressure Plate.
- 12. To authorize the County Judge to submit a request for economic development funds forfeited by Deep East Texas Electric Coop and other electric coops as unclaimed capital credits.
- 13. To discuss and act upon approving the purchase of one (1) G-3 Aluminum Boat through Plano Marine for use by the Panola County Sheriff's Department to be paid for from seized and forfeited assets
- 14. To discuss and act upon approving an Extended Warranty and Service Policy Program with QT Technologies for the credit card machines at Panola County Airport - Sharpe Field.

ADJOURNMENT

WITNESS THE HAND OF THE UNDERSIGNED CLERK ON THIS THE 20TH DAY OF FEBRUARY, 2014 AT 3:05 O'CLOCK P M.



Clara Jones
 CLARA JONES, COUNTY CLERK
 PANOLA COUNTY, TEXAS
 By: Hilandus, Deputy

I, CLARA JONES, CLERK OF THE COMMISSIONERS' COURT OF PANOLA COUNTY, TEXAS DO HEREBY CERTIFY THAT THE ABOVE NOTICE WAS POSTED ON THE OFFICIAL BULLETIN BOARD IN THE PANOLA COUNTY COURTHOUSE IN THE CITY OF CARTHAGE, TEXAS AND IN A PUBLIC PLACE VISIBLE AT ALL TIMES ON THE 20TH DAY OF FEBRUARY, 2014 AT 3:15 O'CLOCK P M

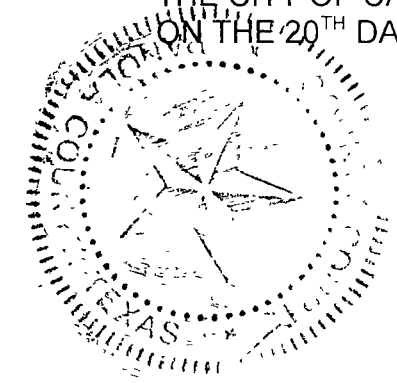

Clara Jones
 CLARA JONES, COUNTY CLERK
 PANOLA COUNTY, TEXAS
 By: Hilandus, Deputy

FILED FOR RECORD
IN MY OFFICE

10:25 O'CLOCK A. M.

MAR 11 2014

CLARA JONES
COUNTY CLERK, PANOLA COUNTY, TEXAS

BY Clara Jones DEBBY

The State of Texas
The County of Panola

On this the 24th day of February, 2014 A.D. the Commissioners' Court of Panola County, Texas met in a Special Meeting of the Court at 9:00 o'clock a.m. in the Commissioners' Courtroom of said County with the following members of the Court present:

David L. Anderson	County Judge
Ronnie LaGrone	Commissioner, Precinct #1
John Gradberg	Commissioner, Precinct #2
Frank R. Langley, Jr.	Commissioner, Precinct #3
Dale LaGrone	Commissioner, precinct #4

with none absent, constituting a quorum of the Court. Also attending were Clara Jones, County Clerk, and Lee Ann Jones, Administrative Assistant to the County Judge. Attached to and made a part of these minutes is a list of other attendees and the office or organization that each represents. The following proceedings were held at this meeting:

OPEN MEETING:

PRAYER: The Prayer was given by Commissioner Ronnie LaGrone.

1. CITIZEN COMMENTS:

Butch Marsalis came before the court to discuss eminent domain in other states.

2. COMMISSIONERS' REPORTS:

Commissioner Ronnie LaGrone reported that the gas pumps are up and running smoothly. Commissioner LaGrone also reminded the Court that the Livestock Show is going on this week. He encouraged everyone to go out and support the youths

3. COUNTY JUDGE'S REPORT:

Judge Anderson reported that this week is the last week for Early Voting.

4. CONSENT ITEMS:

PERSONNEL

- a. To record an increase in salary to \$13.93 per hour for Amanda Walker Geddie, permanent part-time Deputy Clerk in the Panola County Auto Registration Office, effective February 24, 2014.
- b. To record the retirement of Linda Howard as Technical Services Coordinator with the Sammy Brown Library effective March 31, 2014.
- c. To record the retirement of Perry Pitts, an Operator with the Panola County Road and Bridge Department, Precinct #2, effective February 28, 2014.

ROAD & BRIDGE

- a. To approve and record a request by Murvaul Gas Gathering, LLC to cross under Panola County Road #221 with a 12.75 inch line.
- b. To approve and record a request by Murvaul Gas Gathering, LLC to cross under Panola County Road #225 with a 12.75 inch line.
- c. To approve and record a request by Murvaul Gas Gathering, LLC to cross under Panola County Road #274 with a 12.75 inch line.

MISCELLANEOUS

- a. To record Statement of Officer and Oath of Office forms for Panola County Deputy Constable, Precincts #2 and #3, Daniel McMillen.
- b. To approve and record 2014 Budget Amendment No. 5.
- c. To record Panola County Sheriff's State Forfeiture Amendment No.1 for Fiscal Year 2014.

REQUESTS FOR CONFERENCE ATTENDANCE

- a. To approve and record a Request for Attendance at a Conference for the following Panola County elected official(s)/employee(s): Panola County Assistant Criminal District Attorney Katie Nielsen; PCSD Sgt. Jeff Ivy; and PCSD Investigator James Ferris.

Commissioner Dale LaGrone moved and Commissioner John Gradberg seconded the motion to approve all the Consent Items. The motion passed unanimously.

A COPY OF EACH LETTER, AMENDMENT, REQUEST, AND/OR BOND IS ATTACHED TO AND MADE A PART OF THE MINUTES.

5. Commissioner Ronnie LaGrone moved and Commissioner Frank Langley seconded the motion to approve Road & Bridge requisitions and to approve payment of current Panola County bills as presented on vouchers prepared and submitted by the County Auditor. The motion passed unanimously. SEE COPY OF BILLS ATTACHED.
6. Commissioner Ronnie LaGrone moved and Commissioner John Gradberg seconded the motion to award the lowest and best bid for New Roof on Panola County Sheriff's Department Building Complex to **Curtis-McKinley Roofing & Sheet Metal, Inc.** in the amount of **\$124,600.00**. The motion passed unanimously. SEE COPY OF BID ATTACHED.
7. Commissioner Dale LaGrone moved and Commissioner Ronnie LaGrone seconded the motion to appoint Jim Stevens, Pastor Carl Anderson, Ms. Fatha Burchette, Reverend Steve Jackson, and Reverend Mervyn Scott to the Sexually Oriented Business Order, Permit and License Appeal Board for a one year term commencing February 27, 2014 and ending February 27, 2015. The motion passed unanimously. SEE COPY OF APPOINTMENT ATTACHED.
8. Commissioner Frank Langley moved and Commissioner Dale LaGrone seconded the motion approving an update to Panola County's TxCDBG Citizen Complaint Procedures as required by the Texas Community Development Block Grant Program. The motion passed unanimously.
9. Commissioner Ronnie LaGrone moved and Commissioner John Gradberg seconded the motion proclaiming April, 2014 as Fair Housing Month in Panola County. The motion passed unanimously. SEE COPY OF PROCLAMATION ATTACHED.

10. Commissioner Dale LaGrone moved and Commissioner Frank Langley seconded the motion approving a contract between East Texas Council of Governments and Panola County with regards to the Regional Evaluation Services for Juveniles. The motion passed unanimously. SEE COPY OF CONTRACT ATTACHED.

11. Commissioner Ronnie LaGrone moved and Commissioner Frank Langley seconded the motion declaring the following property as surplus property; one (1) 7 x 14 cattle guard; one (1) Delta 78 gallon L shaped fuel tank; one (1) Hyster Grid Packer/Roller; Miscellaneous tires and rims; six (6) sets of Caterpillar Cutting Edges; and one (1) Massey Ferguson 492 Clutch and Pressure Plate. The motion passed unanimously. SEE LIST ATTACHED.

12. Commissioner Dale LaGrone moved and Commissioner Ronnie LaGrone seconded the motion to authorize the County Judge to submit a request for economic development funds forfeited by Deep East Texas Electric Coop and other electric coops as unclaimed capital credits. The motion passed unanimously.

13. Commissioner Ronnie LaGrone moved and Commissioner Frank Langley seconded the motion approving the purchase of one (1) G-3 Aluminum Boat through Plano Marine for use by the Panola County Sheriff's Department to be paid for from seized and forfeited assets. The motion passed unanimously.

14. Commissioner Ronnie LaGrone moved and Commissioner Frank Langley seconded the motion approving an Extended Warranty and Service Policy Program with QT Technologies for the Credit Card Machines at Panola County Airport- Sharpe Field. The motion passed unanimously.

The meeting was then adjourned.

Dated this the 24th day of February, 2014

David L. Anderson, County Judge, Panola County, Texas

ATTEST:

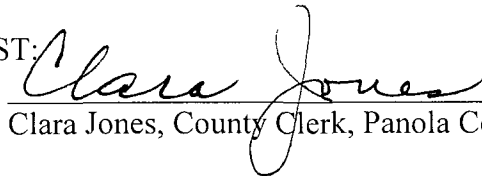
Clara Jones, County Clerk, Panola County, Texas



Commissioner Court Minutes
Feb. 24, 2014

VOL.

87 PAGE
445

1. Scott Jones
2. J. G. M. Lane
3. Rhonda Bidsong
4. Mary Ellen Slegel
5. Richard Jordan
6. Anthony McKinley
7. Ruth Ann
8. Kim Hodder
9. Karen Marsalis
10. William B. (Butch) Marsalis
11. Gloria Potman
12. May Kay Thorne
13. K. Baker
14. Jill Scabar
15. Phil Holder
16. Delma Johnson
- 17.
- 18.

CONSENT

ITEMS

County Of Panola

DEBBIE CRAWFORD
TAX ASSESSOR - COLLECTOR

PANOLA COUNTY COURTHOUSE
110 S SYCAMORE ROOM 211
CARTHAGE, TEXAS 75633

(903) 693-0340

February 11, 2014

Panola County Commissioners Court
Panola County Courthouse

Gentlemen:

Please record the salary increase from \$12.00 per hour to \$13.93 per hour for Amanda Walker Geddie , permanent part-time Deputy Clerk in the Panola County Auto Registration Office, effective February 24, 2014.

Thank you for your continued support and cooperation.

Sincerely,



Debbie Crawford
Panola County Tax Assessor-Collector

cc: Gloria Portman, County Treasurer
Sidney Burns, County Auditor



319 S. MARKET ST. P.O. BOX 328 CARTHAGE, TX 75633
PHONE 903-693-6741

February 6, 2014

Honorable Judge Anderson
County Commissioners Court
Panola County Court House
Carthage, Texas 75633

Dear Sirs,

I'm writing to inform you that Linda Howard is retiring as Technical Services Coordinator at the Sammy Brown Library effective on March 31, 2014.

Sincerely,

A handwritten signature in cursive script that reads "Debra Godwin".

Debra Godwin
Library Director

cc: Sidney Burns
Gloria Portman



Panola County Commissioners

County Courthouse
110 S. Sycamore Street, Room 102-A
Carthage, Texas 75633
(903) 693-0385
Fax: (903) 693-0342

Panola County Commissioner's Court

Please record the retirement of Perry Pitts with Panola County Road & Bridge, Precinct #2, effective February 28, 2014

Sincerely

A handwritten signature in cursive script that reads "John W. Gradberg".

John W Gradberg
Commissioner, Pct. #2

JWG/jr

**NOTICE OF PROPOSED INSTALLATION
PIPELINE AND/OR UTILITY LINES**

TO: THE PANOLA COUNTY COMMISSIONER'S COURT

c/o John W. Gradberg, Pct. 2 Commissioner

PANOLA COUNTY ROAD & BRIDGE DEPARTMENT, CARTHAGE, TEXAS

Formal notice is hereby given that:

MURVAUL GAS GATHERING, LLC proposes to place a
(COMPANY NAME)

12.75 inch line within the Right-of-Way
(PIPE SIZE)

of County Road: 221 as follows:
(NUMBER OF ROAD)

The proposed pipeline will cross under the indicated roads on the attached sheet. Installation shall be made by boring a total length of _____ line in Panola County.

The location and description of the proposed line and appurtenances is more fully shown by the copies of the drawings attached to this notice. The line will be constructed and maintained on the County Right-of-Way as directed by the County Commissioners in accordance with current Panola County Specifications.

Construction of this line will begin on or after the _____ day of _____, 2014.

FIRM: SunDial Energy, LLC
BY: Jay D. Smith
TITLE: Contract Land Agent
ADDRESS: 1201 N. St. Mary Drive
Carthage, Texas
PHONE: (936) 635-7950

**SPECIAL SPECIFICATIONS
FOR PIPELINES CROSSING IN BORED HOLES
AND PLACED PARALLEL TO COUNTY ROADS**

GENERAL NOTE: The construction of this project shall follow "The Panola County Road and Bridge Department Standard Specifications" with respect to barricades, flagmen, flares, warning signs, and all responsibility for complaints or damage suits by traveling public and adjacent property owners.

1. Exaction material shall not be placed on road shoulders or traffic lanes or in ditches where drainage would be impaired. When excavation is permitted near the roadway, where, in the opinion of the County, the support of the oil road structure is endangered, sheeting, cribbing, other measures shall be taken to prevent damage to the roadway or the creation of traffic hazard.
2. All excavations shall be backfilled in a neat and workmanlike manner and all disturbed areas shall be restored to a condition comparable to the original condition. Backfill material shall be consolidated to a density comparable to that of the adjacent undisturbed material, replacing all of the excavated material except that displaced by pipe. The degree of compaction shall be such as to prevent future settlement. Excess material displaced by the pipe shall be removed from the right-of-way or otherwise disposed of to the satisfaction of the county's representative. Pipe laying operation shall not be carried on when soil conditions are such that construction equipment will cause rutting. Backfill operations shall be kept within one mile of trenching and/or pipe laying operations.
3. Sod and/or other erosion control measures removed or disturbed by the installation shall be replaced. This shall include keeping separate and replacing existing topsoil, importing sod or seeding or a combination of these methods together with fertilizer and water as necessary to re-establish vegetative cover in a healthy and growing condition.
4. The pipe or, if encased, the encasement pipe shall completely fit the bored hole.
5. All private and commercial access driveways disturbed by pipe laying shall be restored to a condition comparable to that which existed prior to these operations. Special care shall be taken to compact backfill and base material to prevent future settlement. All work shall be complete to the owner's satisfaction. All public access driveways with paved surfaces shall be crossed by the bored hole method. Crossings of dirt or gravel public access driveways may be made as specified for private and commercial access driveways except that provisions shall be made for uninterrupted flow of traffic.

6. No trees or shrubbery shall be cut or trimmed without the approval of the Panola County Road and Bridge Department.
7. Regulations and ordinances of incorporated cities shall be complied with, if within the city limits.

Commissioners:

Precinct # 1 Ronnie LaGrone
Precinct # 2 John W. Gradberg
Precinct # 3 Frank R. Langley, Jr.
Precinct # 4 Dale LaGrone

APPROVAL

February 24, 2014

TO: Murvaul Gas Gathering, LLC
c/o Mr. Jay D. Smith
SunDial Energy, LLC
1201 N St Mary
Carthage, Texas 75633

RE: **CR #221**

The Panola County Commissioners' Court offers no objection to the location on the right-of-way of your proposed **12.75 inch** line as shown by accompanying drawings and notice except as noted below.

It is expressly understood that the County Commissioners' Court does not purpose hereby, to grant any right, claim, title or easement in or upon this county road. It is further understood that in the future should for any reason the county need to work, improve, relocate, widen, increase, add to, or in any manner change the structure of this right-of-way, any required relocation of said lines shall be at the sole expense of owner

All work on the county right-of-way shall be performed in accordance with the county instructions. The installations shall not damage any part of the road and adequate provisions must be made to cause minimum inconvenience to traffic and adjacent owners. Special specifications for placing this line are as follows:

- 1 All lines are to be installed a minimum of 36 inches below the flow line of the adjacent drainage or barrow ditch.
2. All excavation within the right-of-way and not under surfacing shall be backfilled by tamping in 6 inch horizontal layers. All surplus material shall be removed from the right-of-way and the excavation finished flush with surrounding natural ground.
- 3 Lines crossing under surfaced roads and under surfacing cross roads within the right-of-way shall be placed by boring Boring shall extend from crown line to crown line. Gravity from sewer lines under roadways shall be cast iron pipe
4. All lines, where practicable, shall be located to cross roadbed at approximately right angles thereto. No lines are to be installed under or within 50 feet of either end of any bridge. No lines shall be placed in any culvert or within 10 feet of the closest point of same.

5. Parallel line will be installed as near the right-of-way lines as is possible and no parallel line will be installed in the roadbed or between the drainage ditch and the roadbed without special permission of the Panola County Commissioners' Court.
6. Operations along roadbeds shall be performed in such manner that all excavated material be kept off the pavement at all times, as well as all operating equipment and materials. No equipment or installation procedures will be used which will damage any road surface or structures. The cost of any repairs to road surface, roadbed, structures or other right-of-way features as a direct result of this installation will be borne by the owner of this line.
7. Barricades, warning signs, lights, and flag man(men) when necessary shall be provided by the contractor or owner. One-half (1/2) of the traveled portion of the road must be open at all times

Approved: _____



COUNTY JUDGE

COMMISSIONERS

Precinct #1 Ronnie LaGrone
Precinct #2 John Gradberg
Precinct #3 Frank R. Langley, Jr.
Precinct #4 Dale LaGrone

A. SAMFORD SURVEY
ABSTRACT NO. 632

GRID BEARING
TX N C Z
NAD 83(86)

CALL 18 841 AC
ALVIN BERNARD JONES, ET AL
VOL 904, PG 1

CALL 11 67 AC (NINTH TRACT)
ASHLEE ALLISON ALEXANDER, ET VIR
VOL 1380, PG 255



P/L STA. 87+35
PROPOSED PIPELINE
CROSSING C/L C.R. NO. 221
LAT: 32°11'23.8" N: 6776438.65
LONG: -94°25'45.4" E: 3227546.43
BEING LOCATED NORTHEASTERLY 719'
FROM INTERSECTION F.M. ROAD NO. 959

- 86+64 GROUND
- 87+17 FENCE
- 87+19 TOP SLOPE
- 87+23 PROPERTY LINE
- 87+24 DITCH
- 87+25 BURIED TELEPHONE
- 87+26 EDGE ROAD
- 87+35 C/L C R 221
- 87+44 EDGE ROAD
- 87+50 DITCH
- 87+56 TOP SLOPE
- 87+58 FENCE/POWERLINE
- 87+69 PIPELINE
- 88+07 GROUND

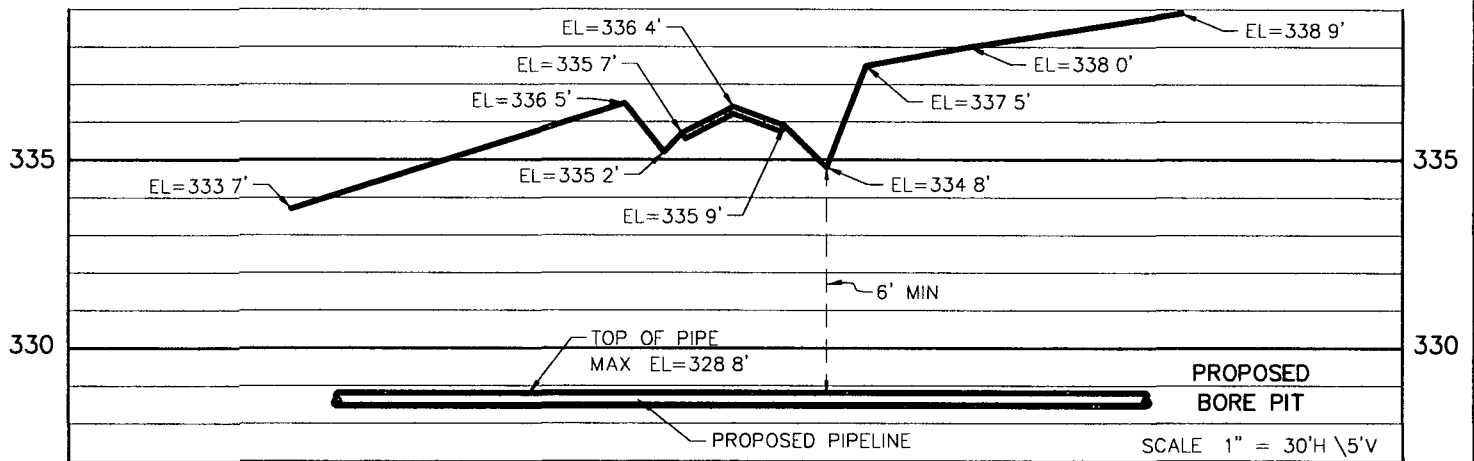

ELEVATION VIEW OF PROPOSED PIPELINE CROSSING C.R. NO. 221

MURVAUL GAS GATHERING, L.L.C.

PROPOSED PIPELINE CROSSING
COUNTY ROAD NO. 221
PANOLA COUNTY, TEXAS

LONGTAIL PIPELINE	DATE 02/11/14
JOB NO C140001 (CR 221)	SCALE 1" = 30'H \5'V

WARNING! UNDERGROUND UTILITIES SHOWN HEREON ARE APPROXIMATE ONLY
THERE MAY ALSO BE OTHER UNDERGROUND UTILITIES THAT ARE NOT SHOWN
BEFORE ANY EXCAVATION OR CONSTRUCTION OPERATIONS BEGIN THE CONTRACTOR
MUST CONTACT ONE CALL UTILITY LOCATION SERVICES AND THE OWNERS OF
THE UTILITIES TO VERIFY THEIR LOCATION
FOR MORE INFORMATION FOR PROJECTS IN TEXAS
SEE THE RRC WEB SITE AT <http://www.rrc.state.tx.us/divisions/gs/pls/onecall.html>

**NOTICE OF PROPOSED INSTALLATION
PIPELINE AND/OR UTILITY LINES**

TO: THE PANOLA COUNTY COMMISSIONER'S COURT

c/o John W. Gradberg, Pct. 2 Commissioner

PANOLA COUNTY ROAD & BRIDGE DEPARTMENT, CARTHAGE, TEXAS

Formal notice is hereby given that:

MURVAUL GAS GATHERING, LLC proposes to place a
(COMPANY NAME)

12.75 inch line within the Right-of-Way
(PIPE SIZE)

of County Road: 225 as follows:
(NUMBER OF ROAD)

The proposed pipeline will cross under the indicated roads on the attached sheet.
Installation shall be made by boring a total length of _____ line in Panola County.

The location and description of the proposed line and appurtenances is more fully shown
by the copies of the drawings attached to this notice. The line will be constructed and
maintained on the County Right-of-Way as directed by the County Commissioners in
accordance with current Panola County Specifications.

Construction of this line will begin on or after the _____ day of
_____, 2014.

FIRM: SunDial Energy, LLC
BY: Jay D. Smith
TITLE: Contract Land Agent
ADDRESS: 1201 N. St. Mary Drive
Carthage, Texas
PHONE: (936) 635-7950

**SPECIAL SPECIFICATIONS
FOR PIPELINES CROSSING IN BORED HOLES
AND PLACED PARALLEL TO COUNTY ROADS**

GENERAL NOTE: The construction of this project shall follow "The Panola County Road and Bridge Department Standard Specifications" with respect to barricades, flagmen, flares, warning signs, and all responsibility for complaints or damage suits by traveling public and adjacent property owners.

1. Exaction material shall not be placed on road shoulders or traffic lanes or in ditches where drainage would be impaired. When excavation is permitted near the roadway, where, in the opinion of the County, the support of the oil road structure is endangered, sheeting, cribbing, other measures shall be taken to prevent damage to the roadway or the creation of traffic hazard.
2. All excavations shall be backfilled in a neat and workmanlike manner and all disturbed areas shall be restored to a condition comparable to the original condition. Backfill material shall be consolidated to a density comparable to that of the adjacent undisturbed material, replacing all of the excavated material except that displaced by pipe. The degree of compaction shall be such as to prevent future settlement. Excess material displaced by the pipe shall be removed from the right-of-way or otherwise disposed of to the satisfaction of the county's representative. Pipe laying operation shall not be carried on when soil conditions are such that construction equipment will cause rutting. Backfill operations shall be kept within one mile of trenching and/or pipe laying operations.
3. Sod and/or other erosion control measures removed or disturbed by the installation shall be replaced. This shall include keeping separate and replacing existing topsoil, importing sod or seeding or a combination of these methods together with fertilizer and water as necessary to re-establish vegetative cover in a healthy and growing condition.
4. The pipe or, if encased, the encasement pipe shall completely fit the bored hole.
5. All private and commercial access driveways disturbed by pipe laying shall be restored to a condition comparable to that which existed prior to these operations. Special care shall be taken to compact backfill and base material to prevent future settlement. All work shall be complete to the owner's satisfaction. All public access driveways with paved surfaces shall be crossed by the bored hole method. Crossings of dirt or gravel public access driveways may be made as specified for private and commercial access driveways except that provisions shall be made for uninterrupted flow of traffic.

6. No trees or shrubbery shall be cut or trimmed without the approval of the Panola County Road and Bridge Department.
7. Regulations and ordinances of incorporated cities shall be complied with, if within the city limits.

Commissioners:

Precinct # 1 Ronnie LaGrone
Precinct # 2 John W. Gradberg
Precinct # 3 Frank R. Langley, Jr.
Precinct # 4 Dale LaGrone

APPROVAL

February 24, 2014

TO: Murvaul Gas Gathering, LLC
c/o Mr. Jay D. Smith
SunDial Energy, LLC
1201 N. St. Mary
Carthage, Texas 75633

RE: **CR #225**

The Panola County Commissioners' Court offers no objection to the location on the right-of-way of your proposed **12.75 inch** line as shown by accompanying drawings and notice except as noted below.

It is expressly understood that the County Commissioners' Court does not purpose hereby, to grant any right, claim, title or easement in or upon this county road. It is further understood that in the future should for any reason the county need to work, improve, relocate, widen, increase, add to, or in any manner change the structure of this right-of-way, any required relocation of said lines shall be at the sole expense of owner.

All work on the county right-of-way shall be performed in accordance with the county instructions. The installations shall not damage any part of the road and adequate provisions must be made to cause minimum inconvenience to traffic and adjacent owners. Special specifications for placing this line are as follows:

- 1 All lines are to be installed a minimum of 36 inches below the flow line of the adjacent drainage or barrow ditch
2. All excavation within the right-of-way and not under surfacing shall be backfilled by tamping in 6 inch horizontal layers. All surplus material shall be removed from the right-of-way and the excavation finished flush with surrounding natural ground.
- 3 Lines crossing under surfaced roads and under surfacing cross roads within the right-of-way shall be placed by boring. Boring shall extend from crown line to crown line. Gravity from sewer lines under roadways shall be cast iron pipe.
4. All lines, where practicable, shall be located to cross roadbed at approximately right angles thereto. No lines are to be installed under or within 50 feet of either end of any bridge. No lines shall be placed in any culvert or within 10 feet of the closest point of same

5. Parallel line will be installed as near the right-of-way lines as is possible and no parallel line will be installed in the roadbed or between the drainage ditch and the roadbed without special permission of the Panola County Commissioners' Court.
6. Operations along roadbeds shall be performed in such manner that all excavated material be kept off the pavement at all times, as well as all operating equipment and materials. No equipment or installation procedures will be used which will damage any road surface or structures. The cost of any repairs to road surface, roadbed, structures or other right-of-way features as a direct result of this installation will be borne by the owner of this line.
7. Barricades, warning signs, lights, and flag man(men) when necessary shall be provided by the contractor or owner. One-half (1/2) of the traveled portion of the road must be open at all times.

Approved: 
COUNTY JUDGE

COMMISSIONERS:

- Precinct #1 Ronnie LaGrone
- Precinct #2 John Gradberg
- Precinct #3 Frank R Langley, Jr.
- Precinct #4 Dale LaGrone

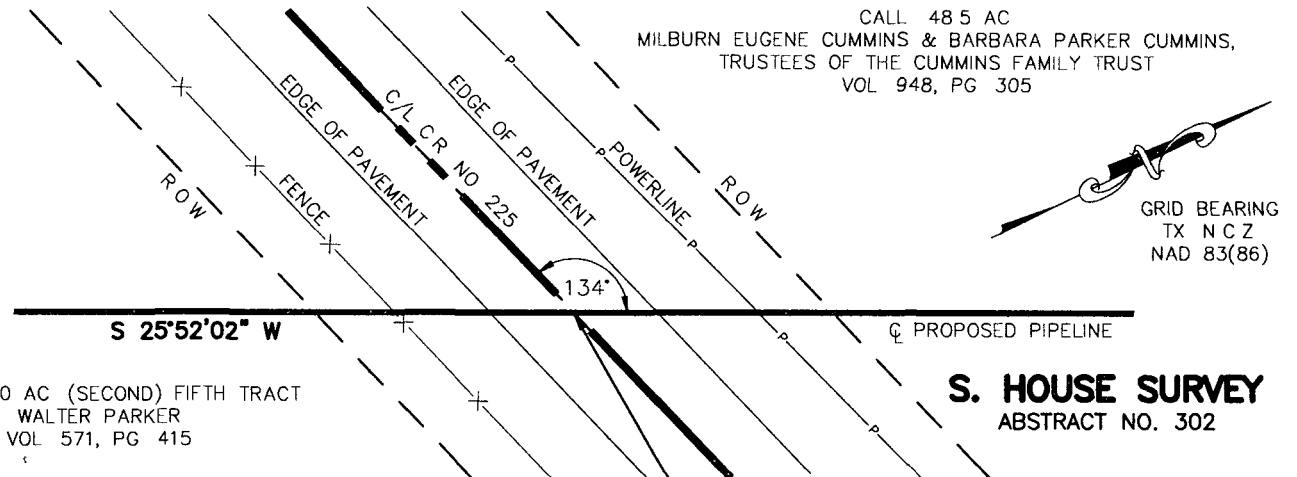

CALL 48.5 AC
MILBURN EUGENE CUMMINS & BARBARA PARKER CUMMINS,
TRUSTEES OF THE CUMMINS FAMILY TRUST
VOL 948, PG 305

GRID BEARING
TX N C Z
NAD 83(86)

CALL 55.50 AC (SECOND) FIFTH TRACT
WALTER PARKER
VOL 571, PG 415

S. HOUSE SURVEY
ABSTRACT NO. 302

WM. LIDDY SURVEY
ABSTRACT NO. 398

P/L STA. 158+50
PROPOSED PIPELINE
CROSSING C/L C.R. NO. 225
LAT: 32°10'31.7" N: 6771088.78
LONG: -94°26'13.0" E: 3225384.67
BEING LOCATED SOUTHWESTERLY 2245'
FROM INTERSECTION F.M. ROAD NO. 959

158+97	GROUND	158+97	EDGE ROAD	158+97	POWERLINE	158+10	TOP SLOPE	157+97	DITCH	157+78	GROUND
158+92	R.O.W.	158+80	FENCE	158+62	C/L C.R. 225	158+08	R.O.W.	157+92	TOP SLOPE		

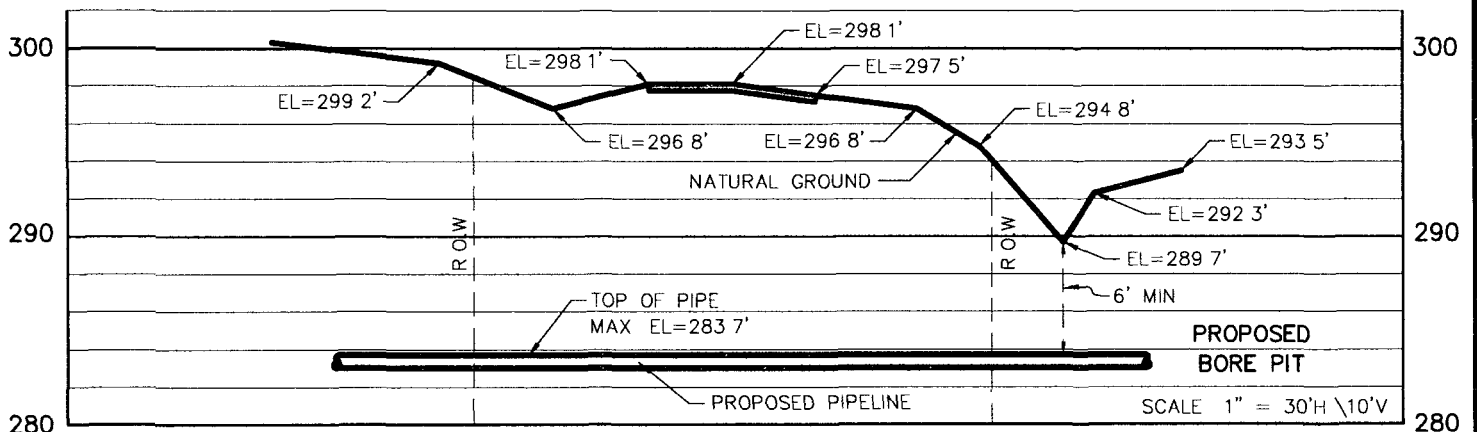

ELEVATION VIEW OF PROPOSED PIPELINE CROSSING C.R. NO. 225

MURVAUL GAS GATHERING, L.L.C.

**PROPOSED PIPELINE CROSSING
COUNTY ROAD NO. 225
PANOLA COUNTY, TEXAS**

WARNING! UNDERGROUND UTILITIES SHOWN HEREON ARE APPROXIMATE ONLY.
THERE MAY ALSO BE OTHER UNDERGROUND UTILITIES THAT ARE NOT SHOWN
BEFORE ANY EXCAVATION OR CONSTRUCTION OPERATIONS BEGIN THE CONTRACTOR
MUST CONTACT ONE CALL UTILITY LOCATION SERVICES AND THE OWNERS OF
THE UTILITIES TO VERIFY THEIR LOCATION
FOR MORE INFORMATION FOR PROJECTS IN TEXAS
SEE THE RRC WEB SITE AT <http://www.rrc.state.tx.us/divisions/gs/pls/onecall.html>

LONGTAIL PIPELINE	DATE 02/10/14
JOB NO C140001 (CR 225)	SCALE 1" = 30'H \ 10'V

**NOTICE OF PROPOSED INSTALLATION
PIPELINE AND/OR UTILITY LINES**

TO: THE PANOLA COUNTY COMMISSIONER'S COURT

c/o John W. Gradberg, Pct. 2 Commissioner

PANOLA COUNTY ROAD & BRIDGE DEPARTMENT, CARTHAGE, TEXAS

Formal notice is hereby given that:

MURVAUL GAS GATHERING, LLC proposes to place a
(COMPANY NAME)

12.75 inch line within the Right-of-Way
(PIPE SIZE)

of County Road: 274 as follows:
(NUMBER OF ROAD)

The proposed pipeline will cross under the indicated roads on the attached sheet. Installation shall be made by boring a total length of _____ line in Panola County.

The location and description of the proposed line and appurtenances is more fully shown by the copies of the drawings attached to this notice. The line will be constructed and maintained on the County Right-of-Way as directed by the County Commissioners in accordance with current Panola County Specifications.

Construction of this line will begin on or after the _____ day of _____,

FIRM: SunDial Energy, LLC
BY: Jay D. Smith
TITLE: Contract Land Agent
ADDRESS: Carthage, Texas
PHONE: (936) 635-7950

**SPECIAL SPECIFICATIONS
FOR PIPELINES CROSSING IN BORED HOLES
AND PLACED PARALLEL TO COUNTY ROADS**

GENERAL NOTE: The construction of this project shall follow "The Panola County Road and Bridge Department Standard Specifications" with respect to barricades, flagmen, flares, warning signs, and all responsibility for complaints or damage suits by traveling public and adjacent property owners.

1. Exaction material shall not be placed on road shoulders or traffic lanes or in ditches where drainage would be impaired. When excavation is permitted near the roadway, where, in the opinion of the County, the support of the oil road structure is endangered, sheeting, cribbing, other measures shall be taken to prevent damage to the roadway or the creation of traffic hazard.
2. All excavations shall be backfilled in a neat and workmanlike manner and all disturbed areas shall be restored to a condition comparable to the original condition. Backfill material shall be consolidated to a density comparable to that of the adjacent undisturbed material, replacing all of the excavated material except that displaced by pipe. The degree of compaction shall be such as to prevent future settlement. Excess material displaced by the pipe shall be removed from the right-of-way or otherwise disposed of to the satisfaction of the county's representative. Pipe laying operation shall not be carried on when soil conditions are such that construction equipment will cause rutting. Backfill operations shall be kept within one mile of trenching and/or pipe laying operations.
3. Sod and/or other erosion control measures removed or disturbed by the installation shall be replaced. This shall include keeping separate and replacing existing topsoil, importing sod or seeding or a combination of these methods together with fertilizer and water as necessary to re-establish vegetative cover in a healthy and growing condition.
4. The pipe or, if encased, the encasement pipe shall completely fit the bored hole.
5. All private and commercial access driveways disturbed by pipe laying shall be restored to a condition comparable to that which existed prior to these operations. Special care shall be taken to compact backfill and base material to prevent future settlement. All work shall be complete to the owner's satisfaction. All public access driveways with paved surfaces shall be crossed by the bored hole method. Crossings of dirt or gravel public access driveways may be made as specified for private and commercial access driveways except that provisions shall be made for uninterrupted flow of traffic.

6. No trees or shrubbery shall be cut or trimmed without the approval of the Panola County Road and Bridge Department.
7. Regulations and ordinances of incorporated cities shall be complied with, if within the city limits.

Commissioners:

Precinct # 1 Ronnie LaGrone
Precinct # 2 John W. Gradberg
Precinct # 3 Frank R. Langley, Jr.
Precinct # 4 Dale LaGrone

APPROVAL

February 24, 2014

TO Murvaul Gas Gathering, LLC
c/o Mr. Jay D. Smith
SunDial Energy, LLC
1201 N St. Mary
Carthage, Texas 75633

RE: **CR #274**

The Panola County Commissioners' Court offers no objection to the location on the right-of-way of your proposed **12.75 inch** line as shown by accompanying drawings and notice except as noted below.

It is expressly understood that the County Commissioners' Court does not purpose hereby, to grant any right, claim, title or easement in or upon this county road. It is further understood that in the future should for any reason the county need to work, improve, relocate, widen, increase, add to, or in any manner change the structure of this right-of-way, any required relocation of said lines shall be at the sole expense of owner.

All work on the county right-of-way shall be performed in accordance with the county instructions. The installations shall not damage any part of the road and adequate provisions must be made to cause minimum inconvenience to traffic and adjacent owners. Special specifications for placing this line are as follows.

1. All lines are to be installed a minimum of 36 inches below the flow line of the adjacent drainage or barrow ditch.
2. All excavation within the right-of-way and not under surfacing shall be backfilled by tamping in 6 inch horizontal layers. All surplus material shall be removed from the right-of-way and the excavation finished flush with surrounding natural ground.
3. Lines crossing under surfaced roads and under surfacing cross roads within the right-of-way shall be placed by boring. Boring shall extend from crown line to crown line. Gravity from sewer lines under roadways shall be cast iron pipe.
4. All lines, where practicable, shall be located to cross roadbed at approximately right angles thereto. No lines are to be installed under or within 50 feet of either end of any bridge. No lines shall be placed in any culvert or within 10 feet of the closest point of same.

5. Parallel line will be installed as near the right-of-way lines as is possible and no parallel line will be installed in the roadbed or between the drainage ditch and the roadbed without special permission of the Panola County Commissioners' Court.
6. Operations along roadbeds shall be performed in such manner that all excavated material be kept off the pavement at all times, as well as all operating equipment and materials. No equipment or installation procedures will be used which will damage any road surface or structures. The cost of any repairs to road surface, roadbed, structures or other right-of-way features as a direct result of this installation will be borne by the owner of this line.
7. Barricades, warning signs, lights, and flag man(men) when necessary shall be provided by the contractor or owner. One-half (1/2) of the traveled portion of the road must be open at all times.

Approved: 
COUNTY JUDGE

COMMISSIONERS:

- Precinct #1 Ronnie LaGrone
- Precinct #2 John Gradberg
- Precinct #3 Frank R. Langley, Jr.
- Precinct #4 Dale LaGrone

DAVID BLANKENSHIP SURVEY

ABSTRACT NO. 48

GRID BEARING
TX N.C.Z
NAD 83(86)

CALL 120 AC
ASHLEY ALEXANDER, ET VIR
VOL 1307, PG 355

CALL 120 AC
JOHN R ALLISON
VOL 1389, PG 18

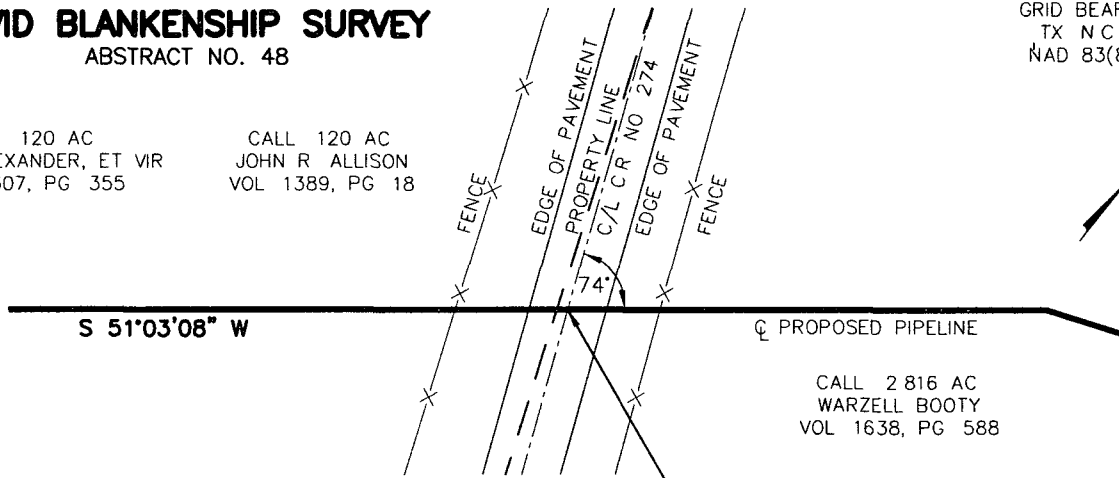

CALL 2 816 AC
WARZELL BOOTY
VOL 1638, PG 588

P/L STA. 15+78
PROPOSED PIPELINE
CROSSING C/L C.R. NO. 274
LAT: 32°12'30.1" N: 6783092.00
LONG: -94°25'59.0" E: 3226123.32
BEING LOCATED SOUTHEASTERLY 840'
FROM INTERSECTION F.M. ROAD NO. 959

16+28	GROUND	15+96	FENCE/TOP SLOPE	15+89	DITCH	15+84	EDGE ROAD	15+80	PROPERTY LINE	15+78	C/L C.R. 274	15+72	EDGE ROAD	15+66	DITCH	15+62	FENCE/TOP SLOPE	15+28	GROUND
-------	--------	-------	-----------------	-------	-------	-------	-----------	-------	---------------	-------	--------------	-------	-----------	-------	-------	-------	-----------------	-------	--------

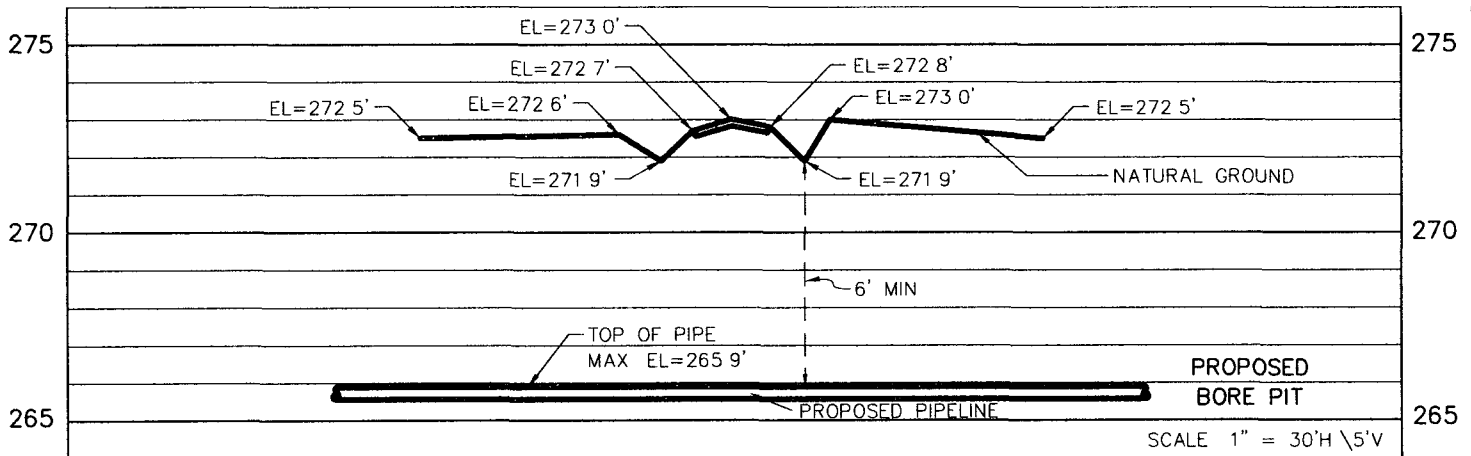

ELEVATION VIEW OF PROPOSED PIPELINE CROSSING C.R. NO. 274

MURVAUL GAS GATHERING, L.L.C.

**PROPOSED PIPELINE CROSSING
COUNTY ROAD NO. 274
PANOLA COUNTY, TEXAS**

WARNING! UNDERGROUND UTILITIES SHOWN HEREON ARE APPROXIMATE ONLY
THERE MAY ALSO BE OTHER UNDERGROUND UTILITIES THAT ARE NOT SHOWN
BEFORE ANY EXCAVATION OR CONSTRUCTION OPERATIONS BEGIN THE CONTRACTOR
MUST CONTACT ONE CALL UTILITY LOCATION SERVICES AND THE OWNERS OF
THE UTILITIES TO VERIFY THEIR LOCATION
FOR MORE INFORMATION FOR PROJECTS IN TEXAS
SEE THE RRC WEB SITE AT <http://www.rrc.state.tx.us/divisions/gs/pls/onecall.html>

LONGTAIL PIPELINE	DATE 02/11/14
JOB NO C140001 (CR 274)	SCALE 1" = 30'H \ 5'V

DEPUTATION

THE STATE OF TEXAS

County of _____ } I, _____

_____ of the County of _____ and State of Texas, having full confidence in _____ of said County and State, do hereby, with the consent of the Honorable Commissioners' Court of _____ County, nominate and appoint _____, the said _____ my true and lawful deputy, in my name, place and stead, to do and perform any and all acts and things pertaining to the office of said _____ of said County and State, hereby ratifying and confirming any and all such acts and things lawfully done in the premises by virtue hereof.

WITNESS my hand, this _____ day of _____ 19_____.

_____ of _____ County, Texas

THE STATE OF TEXAS

County of _____ } BEFORE ME, _____

_____ in and for _____ County, Texas,

on this day personally appeared _____ known to me to be the person whose name is subscribed to the foregoing deputation, and acknowledged to me that he executed the same for the purposes and consideration therein expressed.

GIVEN under my hand and seal of office at _____

this _____ day of _____ 19_____.

OATH OF OFFICE

I, Daniel McMiller do solemnly swear (or affirm) that I will faithfully execute the duties of the office of Dept. Constable 2d3

_____ of the State of Texas, and will to the best of my ability preserve, protect, and defend the Constitution and Laws of the United States and of this State; and I furthermore solemnly swear (or affirm) that I have not, directly nor indirectly, paid, offered or promised to pay, contributed nor promised to contribute, any money or valuable thing, or promised any public office or employment, as a reward to secure my appointment, or the confirmation thereof. So help me God.

Subscribed and sworn to before me, this 10 day of Feb 2014.

[Signature]

County Judge

Form #2201 Rev. 10/2011

This space reserved for office use

Submit to:
SECRETARY OF STATE
Government Filings Section
P O Box 12887
Austin, TX 78711-2887
512-463-6334
512-463-5569 - Fax
Filing Fee: None



STATEMENT OF OFFICER

Statement

I, Daniel McMillen, do solemnly swear (or affirm) that I have not directly or indirectly paid, offered, promised to pay, contributed, or promised to contribute any money or thing of value, or promised any public office or employment for the giving or withholding of a vote at the election at which I was elected or as a reward to secure my appointment or confirmation, whichever the case may be, so help me God.

Position to Which ~~Elected~~ Appointed: Dept. Constable

City and/or County: Panola Co.

Execution

Under penalties of perjury, I declare that I have read the foregoing statement and that the facts stated therein are true.

Date: 2/10/2014

D. J. McMillen
Signature of Officer

Revised 10/2011



PANOLA COUNTY 2014 BUDGET AMENDMENT #5
February 24, 2014

ACCOUNT	ACCOUNT DESCRIPTION	AMOUNT	
GENERAL FUND			
EXPENDITURES			
COMMISSIONERS			
<u>100-401-54200</u>	COMMUNICATION TELEPHONE	(300)	
<u>100-401-54990</u>	MISCELLANEOUS	(200)	
<u>100-401-55270</u>	FURNITURE & EQUIPMENT	500	
			0
			0
			0
GRAND TOTAL GENERAL FUND			
GARY WATER SUPPLY CORPORATION			
REVENUES			
<u>874-330-41260</u>	FEDERAL GRANT	88,042	
			88,042
			88,042
EXPENDITURES			
<u>874-888-55802</u>	WATER IMPROVEMENTS - CONSTRUCTION	63,509	
<u>874-888-55806</u>	WATER IMPROVEMENTS-ENGINEERING	12,625	
<u>874-888-55807</u>	REHAB SINGLE UNIT WATER	5,658	
<u>874-888-55808</u>	GENERAL ADMINISTRATION	6,250	
			88,042
			88,042
			88,042
GRAND TOTAL GARY WSC			
SOUTH MURVAUL WSC			
REVENUES			
<u>876-330-41260</u>	FEDERAL GRANT	225,100	
			225,100
			225,100
EXPENDITURES			
<u>876-888-55802</u>	WATER IMPROVEMENTS CONSTRUCTION	141,450	
<u>876-888-55806</u>	WATER IMPROVEMENTS ENGINEERING	19,500	
<u>876-888-55807</u>	REHAB SINGLE UNIT WATER	44,550	
<u>876-888-55808</u>	GENERAL ADMINISTRATION	19,600	
			225,100
			225,100
			225,100
GRAND TOTAL SOUTH MURVAUL WSC			

PANOLA COUNTY
2014
BUDGET AMENDMENT #5

We hereby amend the Panola County Budget for the Fiscal Year 2014 as set forth above according to the procedures outlined under Vernons Texas Codes Annotated Local Government Code, Chapter 111, Subchapter A Sections 111.010 (d), 111.0106, 111.0107, 111.0108. A copy of this Order is to be filed with the County Clerk and Attached to the Budget originally adopted for 2014.

Signed on this 24th day of February, 2013.

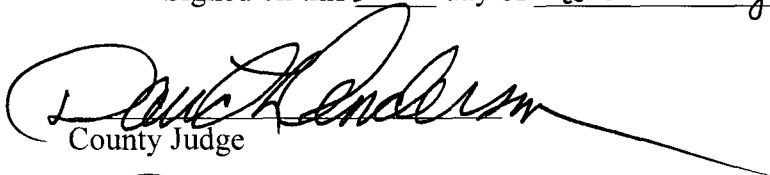
County Judge

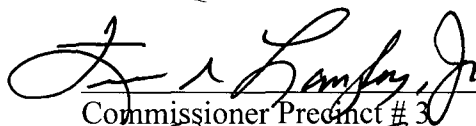

Commissioner Precinct # 1

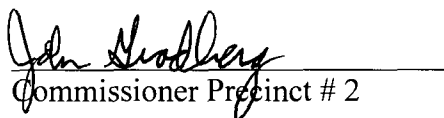
Commissioner Precinct # 3

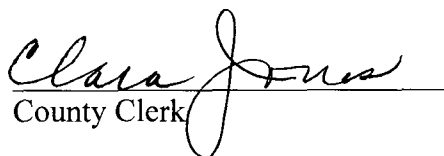

Commissioner Precinct # 2

Commissioner Precinct # 4

Passed and approved by the Commissioners Court of Panola County on the 24th day of February, 2013 as the same appears on file in the office of the County Clerk of Panola County.

County Clerk

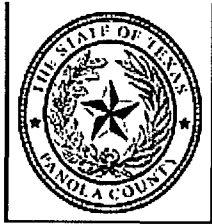



FISCAL YEAR 2014

PANOLA COUNTY SHERIFF STATE FORFEITURE
AMD #1 FEBRUARY 24, 2014

Fund: 800 - SHERIFF'S STATE FORFEITURE

REVENUE

<u>800-360-42000</u>	FORFEITURES	<u><u>4,000</u></u>
----------------------	-------------	---------------------

EXPENSE

<u>800-588-53180</u>	SUPPLIES & EQUIPMENT	1,000
<u>800-588-55270</u>	FURNITURE & EQUIPMENT	3,000

Fund 800 Total:	<u><u>4,000</u></u>
------------------------	---------------------

I hereby approve the above described budget and ask the
Commissioners Court to please record it at the next scheduled
Commissioners Court Meeting.

K. Lake

Kevin Lake, Panola County Sheriff

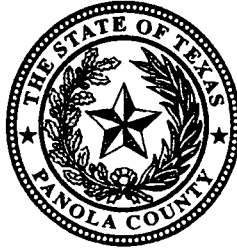

KEN HILL
Assistant District Attorney

KATIE NIELSEN
Assistant District Attorney

KEVIN JONES
Criminal Investigator

123rd JUDICIAL DISTRICT
PANOLA COUNTY, TEXAS

COUNTY COURT AT LAW
PANOLA COUNTY, TEXAS

DANNY BUCK DAVIDSON
Criminal District Attorney

February 10, 2014

Panola County Commissioner's Court

Dear Sirs:

This letter is to request that Katie Nielsen be approved for attendance and expenses to attend the 2014 Intoxication Manslaughter Course in Galveston, Texas beginning April 28, 2014 and ending May 2, 2014.

This seminar is necessary to comply with her CLE for the year.

Sincerely,

A handwritten signature in black ink, appearing to read "Danny Buck Davidson", written over a horizontal line.

Danny Buck Davidson

DBD:je

PANOLA COUNTY OFFICIAL/EMPLOYEE
REQUEST FOR ATTENDANCE
AT A CONFERENCE

APPROVED
02-24-2014
David L. Anderson
David L. Anderson,
County Judge

NAME: Katie Nielsen

POSITION: Assistant Criminal District Attorney

DEPARTMENT: DA

DATE: 2/10/14

CONFERENCE: Investigation & Prosecution of Intoxication Manslaughter

LOCATION: Galveston, TX.

DATES: 4/28/14 to 5/2/14

NUMBER OF DAYS OUT OF OFFICE FOR THIS CONFERENCE: 5

Does the conference meet your educational requirements for the year? Some

If not, how much of your requirements will be met by this conference? most

How much of your requirements have been met already, not counting this conference? almost half

How many days have you been away from your job this year for conferences, not counting this conference? 5

Do you have sufficient funds in your budget for this conference? yes

Write a short statement explaining the public purpose that will be met by your attendance at this conference: (continue on the back if necessary.)

My experience prosecuting Intox Mansl. cases is limited to 4 prior trials, all of which took place nearly a decade ago and involved immediately deceased individuals. I will be trying soon an intox mansl. case with a decedant who lived 18 months after the accident before succumbing =>

to his injuries, and this case is against
a high-profile defense attorney, well-versed in
the current law regarding these matters.
In the interest of justice, and for the sake
of the widow, I need all the knowledge
available to try this case and others like it.

PANOLA COUNTY OFFICIAL/EMPLOYEE
REQUEST FOR ATTENDANCE AT A CONFERENCE

APPROVED
02-24-2014
David L. Anderson
David L. Anderson,
County Judge

NAME: Jeff Ivy
POSITION: Sergeant
DEPARTMENT: Sheriff's Office
DATE: 02/12/2014

CONFERENCE: Electronic Evidence Course
LOCATION: Tyler Junior College Police Academy
DATES: 04/02/2014 to 04/02/2014

NUMBER OF DAYS OUT OF OFFICE FOR THIS CONFERENCE: 1

Does the conference meet your educational requirements for the year? No

If not, how much of your requirements will be met by this conference? 8 hrs

How much of your requirements have been met already, not counting this conference?

How many days have you been away from your job this year for conferences, not counting this conference? _____

Do you have sufficient funds in your budget for this conference? Yes - free

Write a short statement explaining the public purpose that will be met by your attendance at this conference: (continue on the back if necessary.)
Course covers preserving & utilizing electronic evidence as part of criminal investigations

APPROVED

02-24-2014

David L. Anderson
David L. Anderson,
County Judge

PANOLA COUNTY OFFICIAL/EMPLOYEE
REQUEST FOR ATTENDANCE AT A CONFERENCE

NAME: James Ferris
POSITION: Investigator
DEPARTMENT: Sheriff's Office
DATE: 02/12/2014

CONFERENCE: Electronic Evidence Course
LOCATION: Tyler Junior College Police Academy
DATES: 04/02/2014 to 04/02/2014

NUMBER OF DAYS OUT OF OFFICE FOR THIS CONFERENCE: 1

Does the conference meet your educational requirements for the year? No

If not, how much of your requirements will be met by this conference? 8 hrs

How much of your requirements have been met already, not counting this conference?

How many days have you been away from your job this year for conferences, not counting this conference? _____

Do you have sufficient funds in your budget for this conference? Yes - free

Write a short statement explaining the public purpose that will be met by your attendance at this conference: (continue on the back if necessary.)
Covers preserving and utilizing electronic evidence
in criminal investigations

ACTION

ITEMS



Panola County, Texas

VOL. 87 PAGE 479
Payment Register

APPKT02997 - CC PC POOL 2-24-2014

01 - Vendor Set 01

Bank: PANOLA COUNTY POOL - PANOLA COUNTY POOLED CASH

Vendor Number <u>1747</u>	Vendor Filed As A T & T					Total Vendor Amount 164.26
Payment Type Check	Payment Number		Payment Date	Payment Amount		
			02/20/2014	164.26		
Payable Number <u>FEB 28, 2014</u>	Description ACCT#903 693-3763 475 2 - FEB 5 TO MAR 4, 2014	Payable Date 02/19/2014	Due Date 02/19/2014	Discount Amount 0 00	Payable Amount 164.26	

Vendor Number <u>2934</u>	Vendor Filed As A T & T					Total Vendor Amount 2,752.88
Payment Type Check	Payment Number		Payment Date	Payment Amount		
			02/20/2014	2,752.88		
Payable Number <u>FEB 5 2014</u>	Description ACCT#903 693-0300 323 0 - BASE RATE BILLING	Payable Date 02/19/2014	Due Date 02/19/2014	Discount Amount 0.00	Payable Amount 2,752.88	

Vendor Number <u>3265</u>	Vendor Filed As ADVANCED PEST TECHNOLOGY					Total Vendor Amount 540 00
Payment Type Check	Payment Number		Payment Date	Payment Amount		
			02/20/2014	540 00		
Payable Number <u>WEB000015</u>	Description MONTHLY PEST CONTROL	Payable Date 02/13/2014	Due Date 02/13/2014	Discount Amount 0 00	Payable Amount 540 00	

Vendor Number <u>3774</u>	Vendor Filed As AMERICAN TIRE DISTRIBUTORS, INC.					Total Vendor Amount 5,426 40
Payment Type Check	Payment Number		Payment Date	Payment Amount		
			02/21/2014	5,426 40		
Payable Number <u>S042964149</u>	Description P O #57528 - 4 TIRES	Payable Date 02/14/2014	Due Date 02/14/2014	Discount Amount 0 00	Payable Amount 3,617 60	
Payable Number <u>S042964724</u>	Description P O #57534 - TIRES	Payable Date 02/14/2014	Due Date 02/14/2014	Discount Amount 0 00	Payable Amount 1,808.80	

Vendor Number <u>1737</u>	Vendor Filed As AUDIE L. YOUNT					Total Vendor Amount 80 00
Payment Type Check	Payment Number		Payment Date	Payment Amount		
			02/20/2014	80 00		
Payable Number <u>440501</u>	Description JANUARY 2014 GARBAGE TRAILER RENTAL	Payable Date 02/20/2014	Due Date 02/20/2014	Discount Amount 0 00	Payable Amount 80 00	

Vendor Number <u>1898</u>	Vendor Filed As AUTO EXPRESS LUBE					Total Vendor Amount 195 74
Payment Type Check	Payment Number		Payment Date	Payment Amount		
			02/20/2014	195 74		
Payable Number <u>120148</u>	Description VEHICLE MAINTENANCE	Payable Date 02/14/2014	Due Date 02/14/2014	Discount Amount 0 00	Payable Amount 51 62	
Payable Number <u>39628</u>	Description VEHICLE MAINTENANCE	Payable Date 02/14/2014	Due Date 02/14/2014	Discount Amount 0 00	Payable Amount 72 06	
Payable Number <u>39638</u>	Description VEHICLE MAINTENANCE	Payable Date 02/14/2014	Due Date 02/14/2014	Discount Amount 0 00	Payable Amount 57 56	
Payable Number <u>39643</u>	Description VEHICLE INSPECTION	Payable Date 02/14/2014	Due Date 02/14/2014	Discount Amount 0 00	Payable Amount 14 50	

Vendor Number <u>1529</u>	Vendor Filed As BAXTER CLEAN CARE					Total Vendor Amount 1,072 54
Payment Type Check	Payment Number		Payment Date	Payment Amount		
			02/20/2014	1,072 54		
Payable Number <u>188240</u>	Description MISC COURTHOUSE SUPPLIES	Payable Date 02/19/2014	Due Date 02/19/2014	Discount Amount 0 00	Payable Amount 860 23	
Payable Number <u>188255</u>	Description P O #57537 - WIPES AND TRASH BAGS	Payable Date 02/13/2014	Due Date 02/13/2014	Discount Amount 0 00	Payable Amount 212 31	

Payment Register

APPKT02997 - CC PC POOL 2-24-2014

Vendor Number	Vendor Filed As					Total Vendor Amount
<u>3927</u>	BELL SUPPLY COMPANY					22 07
Payment Type	Payment Number			Payment Date	Payment Amount	
Check				02/20/2014	22 07	
Payable Number	Description	Payable Date	Due Date	Discount Amount	Payable Amount	
<u>PSI719534</u>	P O #57584 - NIPPLE	02/19/2014	02/19/2014	0 00	22 07	
<u>1351</u>	BOB BARKER COMPANY INC					350 43
Payment Type	Payment Number			Payment Date	Payment Amount	
Check				02/20/2014	350 43	
Payable Number	Description	Payable Date	Due Date	Discount Amount	Payable Amount	
<u>UT1000304210</u>	FOOD ROTATION LABELS	02/20/2014	02/20/2014	0 00	350.43	
<u>3663</u>	BOBCAT SPECIALTIES, LLC					462 00
Payment Type	Payment Number			Payment Date	Payment Amount	
Check				02/20/2014	462 00	
Payable Number	Description	Payable Date	Due Date	Discount Amount	Payable Amount	
<u>14724</u>	MIC CLIPS	02/13/2014	02/13/2014	0 00	32 00	
<u>14760</u>	PCS PRIMARY CONSOLES SERVICE REPAIRS	02/20/2014	02/20/2014	0 00	430 00	
<u>4169</u>	CAIN HARDWARE & LUMBER					46 18
Payment Type	Payment Number			Payment Date	Payment Amount	
Check				02/20/2014	46 18	
Payable Number	Description	Payable Date	Due Date	Discount Amount	Payable Amount	
<u>00578030</u>	P O #57665 - FILTERS AND DOOR KNOB	02/14/2014	02/14/2014	0.00	24 63	
<u>00578095</u>	FLEXIBLE PVC, FITTINGS AND GALVAN HEX BUSHING	02/13/2014	02/13/2014	0 00	7 19	
<u>00578232</u>	4 XO RUST GRAY METAL PRIMER P O #57669	02/13/2014	02/13/2014	0 00	14 36	
<u>1128</u>	CAR-TEX TRAILER COMPANY, INC					197 07
Payment Type	Payment Number			Payment Date	Payment Amount	
Check				02/20/2014	197 07	
Payable Number	Description	Payable Date	Due Date	Discount Amount	Payable Amount	
<u>144337</u>	P O #57660 - CHANNEL IRON	02/14/2014	02/14/2014	0 00	65 12	
<u>144361</u>	P O #57580 - SLIPPER SPRING	02/14/2014	02/14/2014	0.00	82.00	
<u>144517</u>	P O #57588 - 7 TO 5 TO 4 WAY TRUCK PLUG	02/19/2014	02/19/2014	0 00	49 95	
<u>1618</u>	CARTHAGE AUTOMOTIVE					16 00
Payment Type	Payment Number			Payment Date	Payment Amount	
Check				02/20/2014	16.00	
Payable Number	Description	Payable Date	Due Date	Discount Amount	Payable Amount	
<u>1-40516</u>	REAR TIRE LEAK ON DRIVER'S SIDE	02/14/2014	02/14/2014	0 00	16 00	
<u>1796</u>	CARTHAGE TOWING, LLC					220.00
Payment Type	Payment Number			Payment Date	Payment Amount	
Check				02/20/2014	220.00	
Payable Number	Description	Payable Date	Due Date	Discount Amount	Payable Amount	
<u>1371</u>	WRECKER CALL - UNSTUCK TRUCK	02/20/2014	02/20/2014	0 00	75 00	
<u>1405</u>	WRECKER CALL- 2010 FORD CROWN VIC BROKE DOWN	02/20/2014	02/20/2014	0 00	145 00	
<u>2704</u>	CDW GOVERNMENT, INC.					4,112 84
Payment Type	Payment Number			Payment Date	Payment Amount	
Check				02/20/2014	4,112.84	
Payable Number	Description	Payable Date	Due Date	Discount Amount	Payable Amount	
<u>JG80281</u>	2 - HP SB 6305 A4-5300 500 GB 4GB W7P/W8	02/19/2014	02/19/2014	0 00	841 88	
<u>JN70291</u>	4 - HP SB 6305 A4-5300 500GB 4GB W7P/W8	02/19/2014	02/19/2014	0 00	1,683 76	

Payment Register

<u>JP31588</u>	6 - MS GSA OFFICE STD 2013	02/19/2014	02/19/2014	0 00	1,529 34
<u>JP31942</u>	ITEM #2017281 - MERAKI 11AF POE INJECTOR US PLUGS	02/19/2014	02/19/2014	0 00	207 36
<u>JS61373</u>	2 BLACK AND 2 TRI-COLOR INK CARTRIDGES	02/19/2014	02/19/2014	0.00	116 82
<u>JT36073_CM</u>	RETURNED COMPUTER ITEM #3035769 2-5-2014	02/19/2014	02/19/2014	0.00	-420 94
<u>JT87976</u>	HP CLJ PRO 400 M451NW	02/19/2014	02/19/2014	0 00	361 98
<u>JV63393_CM</u>	RETURNED BOTH OF ITEM #2017281	02/19/2014	02/19/2014	0 00	-207 36
Vendor Number <u>2190</u>	Vendor Filed As CERTIFIED SERVICE CENTER				Total Vendor Amount 198 00
Payment Type Check	Payment Number	Payment Date	Payment Amount		
		02/20/2014	198 00		
Payable Number <u>VA0341-001</u>	Description DISHWASHER REPAIRS	Payable Date 02/19/2014	Due Date 02/19/2014	Discount Amount 0.00	Payable Amount 198 00
Vendor Number <u>3371</u>	Vendor Filed As CHRIS ERVIN				Total Vendor Amount 1,350 00
Payment Type Check	Payment Number	Payment Date	Payment Amount		
		02/20/2014	1,350 00		
Payable Number <u>CCL REV-FEL 2008-C-0132</u>	Description CCL REV-FEL 2008-C-0132 - TX V BRYAN R WEAVER	Payable Date 02/19/2014	Due Date 02/19/2014	Discount Amount 0 00	Payable Amount 450 00
<u>CCL REV-MISD 27967-C</u>	CCL REV-MISD 27967-C - TX V PATRICIA HICKS	02/19/2014	02/19/2014	0 00	450 00
<u>DC FELONY 2010-C-0164</u>	DC FELONY 2010-C-0164 - TX V KATOVNSNA CAPLES	02/19/2014	02/19/2014	0.00	450 00
Vendor Number <u>0148</u>	Vendor Filed As COMPLETE PRINTING & PUBLISHING CO				Total Vendor Amount 73 82
Payment Type Check	Payment Number	Payment Date	Payment Amount		
		02/21/2014	73 82		
Payable Number <u>81829</u>	Description 250 FORMS - WARRANT DOOR HANGERS	Payable Date 02/21/2014	Due Date 02/21/2014	Discount Amount 0 00	Payable Amount 73 82
Vendor Number <u>1774</u>	Vendor Filed As COREY F. BANKHEAD				Total Vendor Amount 450 00
Payment Type Check	Payment Number	Payment Date	Payment Amount		
		02/20/2014	450 00		
Payable Number <u>CCL REV-MISD 27190-C</u>	Description CCL REV-MISD 27190-C - TX V DENISE MONTGOMERY	Payable Date 02/14/2014	Due Date 02/14/2014	Discount Amount 0 00	Payable Amount 450 00
Vendor Number <u>1593</u>	Vendor Filed As COUNTY INFORMATION RESOURCES AGENCY				Total Vendor Amount 170 00
Payment Type Check	Payment Number	Payment Date	Payment Amount		
		02/21/2014	170.00		
Payable Number <u>SOP002003</u>	Description JANUARY 2014 E-MAIL ACCOUNTS \$85 00 @ \$2 00 EA	Payable Date 02/21/2014	Due Date 02/21/2014	Discount Amount 0 00	Payable Amount 170 00
Vendor Number <u>1865</u>	Vendor Filed As CRAIG ELECTRIC				Total Vendor Amount 396 48
Payment Type Check	Payment Number	Payment Date	Payment Amount		
		02/20/2014	396.48		
Payable Number <u>8526</u>	Description EXTENSION OFFICE - CAT 5 COMPUTER CABLE/BOX COVE	Payable Date 02/19/2014	Due Date 02/19/2014	Discount Amount 0 00	Payable Amount 168 98
<u>8529</u>	REPAIR ELEC CIRCUIT-COMPUTER-JOE MIMS' OFFICE	02/19/2014	02/19/2014	0 00	227 50
Vendor Number <u>4091</u>	Vendor Filed As DAVID GRAY				Total Vendor Amount 490 32
Payment Type Check	Payment Number	Payment Date	Payment Amount		
		02/20/2014	40 32		
Payable Number <u>02 20.14</u>	Description MILEAGE REIMB FOR TRAINING IN HENDERSON	Payable Date 02/20/2014	Due Date 02/20/2014	Discount Amount 0 00	Payable Amount 40 32

Payment Register

APPKT02997 - CC PC POOL 2-24-2014

Check	Payable Number	Description	Payable Date	Due Date	Discount Amount	Payable Amount	Total Vendor Amount
	<u>JAN 2014</u>	TRAVEL ADVANCE FOR CONF. IN ROCKWALL, TX	01/15/2014	01/15/2014	0 00	450.00	450 00
Vendor Number	Vendor Filed As						Total Vendor Amount
<u>2312</u>	DEBBIE'S BEST WATER STORE						196 50
Payment Type	Payment Number				Payment Date	Payment Amount	
Check					02/20/2014	196 50	
Payable Number	Description	Payable Date	Due Date	Discount Amount	Payable Amount		
<u>54994</u>	COOLER RENTAL JAN & FEB/ 5 GAL DELIVERED	02/19/2014	02/19/2014	0 00	167 25		
<u>55030</u>	COOLER RENTAL FEB 2014, 5 GAL DEL., SOLO CUPS	02/20/2014	02/20/2014	0 00	29 25		
Vendor Number	Vendor Filed As						Total Vendor Amount
<u>2748</u>	DISH NETWORK SERVICE, LLC						97 62
Payment Type	Payment Number				Payment Date	Payment Amount	
Check					02/20/2014	97 62	
Payable Number	Description	Payable Date	Due Date	Discount Amount	Payable Amount		
<u>FEB 4, 2014</u>	MONTHLY WEATHER SATELLITE 2/17/14 TO 3/16/14	02/20/2014	02/20/2014	0.00	97 62		
Vendor Number	Vendor Filed As						Total Vendor Amount
<u>1584</u>	DLS DETENTION LOCK & EQUIPMENT SERVICE						4,358 00
Payment Type	Payment Number				Payment Date	Payment Amount	
Check					02/20/2014	4,358 00	
Payable Number	Description	Payable Date	Due Date	Discount Amount	Payable Amount		
<u>3438</u>	LOCK REPAIRS	02/14/2014	02/14/2014	0 00	4,358 00		
Vendor Number	Vendor Filed As						Total Vendor Amount
<u>3603</u>	DOGGETT EQUIPMENT SERVICE, LLC						103 56
Payment Type	Payment Number				Payment Date	Payment Amount	
Check					02/20/2014	103 56	
Payable Number	Description	Payable Date	Due Date	Discount Amount	Payable Amount		
<u>K15690</u>	P O #57587 - SUCTION HOSE AND FREIGHT	02/19/2014	02/19/2014	0 00	103.56		
Vendor Number	Vendor Filed As						Total Vendor Amount
<u>1620</u>	DOUBLE "O" CARPENTRY						690 00
Payment Type	Payment Number				Payment Date	Payment Amount	
Check					02/20/2014	690 00	
Payable Number	Description	Payable Date	Due Date	Discount Amount	Payable Amount		
<u>02 18 14</u>	LETTERS PAINTED ON THE FRONT OF THE COURTHOUSE	02/19/2014	02/19/2014	0 00	690 00		
Vendor Number	Vendor Filed As						Total Vendor Amount
<u>1050</u>	DR. KEITH KEELING						500.00
Payment Type	Payment Number				Payment Date	Payment Amount	
Check					02/20/2014	500.00	
Payable Number	Description	Payable Date	Due Date	Discount Amount	Payable Amount		
<u>FEBRUARY 2014</u>	MONTHLY LOCAL HEALTH AUTHORITY FEB 2014	02/19/2014	02/19/2014	0.00	500.00		
Vendor Number	Vendor Filed As						Total Vendor Amount
<u>3572</u>	DRIVERS LICENSE GUIDE COMPANY						29 95
Payment Type	Payment Number				Payment Date	Payment Amount	
Check					02/20/2014	29.95	
Payable Number	Description	Payable Date	Due Date	Discount Amount	Payable Amount		
<u>651711</u>	I.D CHECKING GUIDE	02/14/2014	02/14/2014	0 00	29 95		
Vendor Number	Vendor Filed As						Total Vendor Amount
<u>2982</u>	EAST TEXAS ALARM, INC						22 00
Payment Type	Payment Number				Payment Date	Payment Amount	
Check					02/20/2014	22 00	
Payable Number	Description	Payable Date	Due Date	Discount Amount	Payable Amount		
<u>724774</u>	MONITOR SERVICE-FIRE ALARM FEBRUARY 2014	02/13/2014	02/13/2014	0 00	22 00		

Payment Register

Vendor Number	Vendor Filed As					Total Vendor Amount
<u>2467</u>	EAST TEXAS MEDICAL CENTER CARTHAGE-INDIGENT					22,680.72
Payment Type	Payment Number			Payment Date	Payment Amount	
Check				02/20/2014	22,680.72	
Payable Number	Description	Payable Date	Due Date	Discount Amount	Payable Amount	
<u>BATCH DATE 2/24/14</u>	INDIGENT HEALTHCARE 2013	12/31/2013	12/31/2013	0.00	22,680.72	
<u>3007</u>	ECONO SIGN & BARRICADE, LLC					705.54
Payment Type	Payment Number			Payment Date	Payment Amount	
Check				02/20/2014	705.54	
Payable Number	Description	Payable Date	Due Date	Discount Amount	Payable Amount	
<u>10-913080</u>	P O #57573 - 10. LAMINATED EMBLEM	02/14/2014	02/14/2014	0.00	235.18	
<u>10-913081</u>	P O #57702 - 10" LAMINATED EMBLEMS	02/14/2014	02/14/2014	0.00	235.18	
<u>10-913082</u>	P O #57604 - 10 LAMINATED EMBLEM	02/14/2014	02/14/2014	0.00	235.18	
<u>1798</u>	EDWARD GRIPON, MD PA					9,050.00
Payment Type	Payment Number			Payment Date	Payment Amount	
Check				02/20/2014	9,050.00	
Payable Number	Description	Payable Date	Due Date	Discount Amount	Payable Amount	
<u>TIEBE000</u>	MENTAL EVAL - BERNHARDT TIEDE	02/20/2014	02/20/2014	0.00	9,050.00	
<u>1117</u>	ETMC EMS					79.57
Payment Type	Payment Number			Payment Date	Payment Amount	
Check				02/20/2014	79.57	
Payable Number	Description	Payable Date	Due Date	Discount Amount	Payable Amount	
<u>372</u>	FEBRUARY 2014 ELECTRIC TOWER SITE SERVICES	02/19/2014	02/19/2014	0.00	79.57	
<u>0708</u>	FIRE AND SAFETY EQUIPMENT					221.00
Payment Type	Payment Number			Payment Date	Payment Amount	
Check				02/20/2014	221.00	
Payable Number	Description	Payable Date	Due Date	Discount Amount	Payable Amount	
<u>ORD#4190</u>	P O #57664 - DRUG AND ALCOHOL TESTING	02/14/2014	02/14/2014	0.00	221.00	
<u>1564</u>	FLOWERS BAKING COMPANY OF TYLER LLC					248.79
Payment Type	Payment Number			Payment Date	Payment Amount	
Check				02/20/2014	248.79	
Payable Number	Description	Payable Date	Due Date	Discount Amount	Payable Amount	
<u>44574036</u>	BREAD FOR THE DETENTION CENTER	02/14/2014	02/14/2014	0.00	132.85	
<u>44574242</u>	2/11/14 BREAD FOR DETENTION CENTER	02/19/2014	02/19/2014	0.00	115.94	
<u>1070</u>	GALLS/QUARTERMASTER					368.31
Payment Type	Payment Number			Payment Date	Payment Amount	
Check				02/20/2014	368.31	
Payable Number	Description	Payable Date	Due Date	Discount Amount	Payable Amount	
<u>001548613</u>	ACCT#3866131 - UNIFORM SHIRTS	02/20/2014	02/20/2014	0.00	109.11	
<u>001561281</u>	3 SCORPION MICRO DV RECORDERS @ 86 40 EA	02/13/2014	02/13/2014	0.00	259.20	
<u>1178</u>	GATEWAY TIRE & SERVICE CENTER					35.00
Payment Type	Payment Number			Payment Date	Payment Amount	
Check				02/20/2014	35.00	
Payable Number	Description	Payable Date	Due Date	Discount Amount	Payable Amount	
<u>1501234714</u>	REGULAR MOUNT AND DISPOSAL FEE	02/19/2014	02/19/2014	0.00	35.00	

Payment Register

APPKT02997 - CC PC POOL 2-24-2014

Vendor Number <u>1651</u>	Vendor Filed As GOODWIN LEGAL SERVICES			Total Vendor Amount 2,800.00
Payment Type Check	Payment Number	Payment Date 02/20/2014	Payment Amount 2,800 00	
Payable Number	Description	Payable Date	Due Date	Discount Amount Payable Amount
<u>DC FEL-MISD 2014-C-0020</u>	DC FEL-MISD 2014-C-0020 - TX V JEFFREY R PORTER JR	02/13/2014	02/13/2014	0 00 333 33
<u>DC FEL-MISD 28258-C</u>	DC FEL-MISD 28258-C - JEFFREY R PORTER JR	02/13/2014	02/13/2014	0 00 333.33
<u>DC FEL-MISD 28259-C</u>	DC FEL-MISD 28259-C - TX V JEFFREY R PORTER, JR	02/13/2014	02/13/2014	0.00 333 34
<u>DC FELONY 2009-C-0020</u>	DC FELONY 2009-C-0020 - TX V JOSHUA PIPPEN	02/14/2014	02/14/2014	0 00 450 00
<u>DC FELONY 2014-C-0010</u>	DC FELONY 2014-C-0010 - TX V DENNIS BARTON	02/13/2014	02/13/2014	0.00 450 00
<u>DC FELONY 2014-C-0011</u>	DC FELONY 2014-C-0011 - TX V DENNIS BARTON	02/13/2014	02/13/2014	0 00 450 00
<u>DC FEL-REV 2013-C-0155</u>	DC FEL-REV 2013-C-0155 - TX V JOSIE E WIDENER	02/14/2014	02/14/2014	0.00 450 00

Vendor Number <u>1485</u>	Vendor Filed As GUARDIAN SECURITY SOLUTIONS, LC			Total Vendor Amount 7,465 00
Payment Type Check	Payment Number	Payment Date 02/21/2014	Payment Amount 7,465 00	
Payable Number	Description	Payable Date	Due Date	Discount Amount Payable Amount
<u>10049</u>	JAIL DVR SYSTEM	02/21/2014	02/21/2014	0 00 7,465.00

Vendor Number <u>1646</u>	Vendor Filed As H & H ENGINES AND EQUIPMENT, L L C			Total Vendor Amount 4,801 06
Payment Type Check	Payment Number	Payment Date 02/20/2014	Payment Amount 4,801.06	
Payable Number	Description	Payable Date	Due Date	Discount Amount Payable Amount
<u>82270</u>	P O #57704 - DUMP TRUCK REPAIRS	02/14/2014	02/14/2014	0 00 4,801.06

Vendor Number <u>4111</u>	Vendor Filed As HAWTHORN FUNERAL HOME, LP			Total Vendor Amount 634 00
Payment Type Check	Payment Number	Payment Date 02/20/2014	Payment Amount 634 00	
Payable Number	Description	Payable Date	Due Date	Discount Amount Payable Amount
<u>FEB 9, 2014</u>	MARION ONEIL WHITESIDE 2/8/14 TRANS TO M/E/	02/13/2014	02/13/2014	0 00 634 00

Vendor Number <u>1871</u>	Vendor Filed As JAMES KEITH KNIGHT			Total Vendor Amount 50.00
Payment Type Check	Payment Number	Payment Date 02/20/2014	Payment Amount 50.00	
Payable Number	Description	Payable Date	Due Date	Discount Amount Payable Amount
<u>JAN FEB 2014</u>	JAN AND FEB 2014 PIT LEASE	02/19/2014	02/19/2014	0.00 50 00

Vendor Number <u>2615</u>	Vendor Filed As JENNIFER STACY			Total Vendor Amount 244 51
Payment Type Check	Payment Number	Payment Date 02/20/2014	Payment Amount 244.51	
Payable Number	Description	Payable Date	Due Date	Discount Amount Payable Amount
<u>02 18.04</u>	TRAVEL REIMB FOR CONF. IN AUSTIN, TX	02/19/2014	02/19/2014	0 00 244 51

Vendor Number <u>1793</u>	Vendor Filed As JETT BUSINESS SYSTEMS, INC			Total Vendor Amount 220 53
Payment Type Check	Payment Number	Payment Date 02/20/2014	Payment Amount 220 53	
Payable Number	Description	Payable Date	Due Date	Discount Amount Payable Amount
<u>86422</u>	INK CARTRIDGE AND FREIGHT FOR MAIL MACHINE	02/14/2014	02/14/2014	0 00 220 53

Vendor Number <u>0023</u>	Vendor Filed As JONI REED			Total Vendor Amount 179 31
Payment Type Check	Payment Number	Payment Date 02/20/2014	Payment Amount 179 31	
Payable Number	Description	Payable Date	Due Date	Discount Amount Payable Amount
<u>02.18.14</u>	TRAVEL REIMB FOR CONF IN AUSTIN, TX	02/19/2014	02/19/2014	0 00 179 31

Payment Register

Vendor Number	Vendor Filed As			Total Vendor Amount	
<u>3615</u>	JUST IN TIME SANITATION SERVICES			290 00	
Payment Type	Payment Number	Payment Date	Payment Amount		
Check		02/20/2014	290 00		
Payable Number	Description	Payable Date	Due Date	Discount Amount	Payable Amount
<u>54663</u>	2 PORTABLE TOILET RENTALS JANUARY 2014	02/20/2014	02/20/2014	0 00	140 00
<u>54664</u>	PORTABLE TOILET RENTAL JANUARY 2014	02/14/2014	02/14/2014	0 00	75 00
<u>54665</u>	P O #57604-PORTABLE TOILET RENTAL JANUARY 2014	02/14/2014	02/14/2014	0.00	75 00
<u>1534</u>	KATHERINE T BETZLER			450 00	
Payment Type	Payment Number	Payment Date	Payment Amount		
Check		02/20/2014	450 00		
Payable Number	Description	Payable Date	Due Date	Discount Amount	Payable Amount
<u>CCL REV-MISD 27705-C</u>	CCL REV-MISD 27705-C - TX V GARY GEORGE	02/19/2014	02/19/2014	0 00	450 00
<u>1802</u>	KELLPRO, INC			2,658 00	
Payment Type	Payment Number	Payment Date	Payment Amount		
Check		02/20/2014	2,658.00		
Payable Number	Description	Payable Date	Due Date	Discount Amount	Payable Amount
<u>00129080B</u>	SEQUEL SERVER SERVICES JP 1	02/20/2014	02/20/2014	0 00	1,329.00
<u>00129081B</u>	SEQUEL SERVER SERVICES JP #2	02/20/2014	02/20/2014	0 00	1,329 00
<u>1778</u>	KYLE DANSBY, ATTORNEY AT LAW			400 00	
Payment Type	Payment Number	Payment Date	Payment Amount		
Check		02/20/2014	400.00		
Payable Number	Description	Payable Date	Due Date	Discount Amount	Payable Amount
<u>CCL MISD 28179-C</u>	CCL MISD 28179-C - TX V LEO COOPER	02/19/2014	02/19/2014	0 00	400.00
<u>3795</u>	LAURA M CARPENTER			1,000 00	
Payment Type	Payment Number	Payment Date	Payment Amount		
Check		02/20/2014	1,000 00		
Payable Number	Description	Payable Date	Due Date	Discount Amount	Payable Amount
<u>CCL REV-FEL 2011-C-0280-0</u>	CCL REV-FEL 2011-C-0280-0282 - TX V NETA L SIEGEL	02/14/2014	02/14/2014	0.00	1,000 00
<u>1243</u>	LEXISNEXIS RISK DATA MANAGEMENT, INC			155 00	
Payment Type	Payment Number	Payment Date	Payment Amount		
Check		02/20/2014	155.00		
Payable Number	Description	Payable Date	Due Date	Discount Amount	Payable Amount
<u>1549905-20140131</u>	ACCT#1549905 - JANUARY 2014 SERVICES	02/13/2014	02/13/2014	0 00	155 00
<u>1729</u>	LIQUID CAPITAL EXCHANGE, INC			277 94	
Payment Type	Payment Number	Payment Date	Payment Amount		
Check		02/20/2014	277.94		
Payable Number	Description	Payable Date	Due Date	Discount Amount	Payable Amount
<u>8442</u>	TRANSPORT FROM JONESBORO, AR TO PANOLA COUNTY	02/19/2014	02/19/2014	0 00	277.94
<u>3640</u>	LORA J TAYLOR			428 40	
Payment Type	Payment Number	Payment Date	Payment Amount		
Check		02/20/2014	403 40		
Payable Number	Description	Payable Date	Due Date	Discount Amount	Payable Amount
<u>01/29/2014</u>	TRAVEL ADV FOR CONFERENCE IN ROCKWALL	01/29/2014	01/29/2014	0 00	403.40

Payment Register

APPKT02997 - CC PC POOL 2-24-2014

Check	Payable Number	Description	Payable Date	Due Date	Discount Amount	Payable Amount	
	<u>02 13.14</u>	REIMBURSEMENT FOR REG. FEE - ETJPCA	02/20/2014	02/20/2014	0 00	25 00	02/20/2014 25.00
Vendor Number	Vendor Filed As						Total Vendor Amount
<u>1673</u>	MARIA HERNANDEZ						25.00
Payment Type	Payment Number						Payment Date Payment Amount
Check							02/20/2014 25 00
Payable Number	Description	Payable Date	Due Date	Discount Amount	Payable Amount		
<u>FEB 2014</u>	REIMB FOR 2014 REGISTRATION FEE-ETJPCA MTG	02/20/2014	02/20/2014	0 00	25 00		
Vendor Number	Vendor Filed As						Total Vendor Amount
<u>1394</u>	MATHESON TRI-GAS, INC.						158 29
Payment Type	Payment Number						Payment Date Payment Amount
Check							02/20/2014 158 29
Payable Number	Description	Payable Date	Due Date	Discount Amount	Payable Amount		
<u>08530348</u>	P O #57661 - CYLINDERS	02/14/2014	02/14/2014	0.00	37.20		
<u>08583860</u>	P O #57578 - OXYGEN,ACETYLENE,HAZMAT,TRANS DEL	02/19/2014	02/19/2014	0 00	121 09		
Vendor Number	Vendor Filed As						Total Vendor Amount
<u>1794</u>	MELISSA SAMPSON, MEDIATOR & ATTORNEY @ LAW						450 00
Payment Type	Payment Number						Payment Date Payment Amount
Check							02/20/2014 450 00
Payable Number	Description	Payable Date	Due Date	Discount Amount	Payable Amount		
<u>CCL FELONY 2013-C-0373</u>	CCL FELONY 2013-C-0373 - TX V ROBIN BOSTIC	02/19/2014	02/19/2014	0 00	450 00		
Vendor Number	Vendor Filed As						Total Vendor Amount
<u>1030</u>	MUNICIPAL SERVICES BUREAU						2.34
Payment Type	Payment Number						Payment Date Payment Amount
Check							02/20/2014 2 34
Payable Number	Description	Payable Date	Due Date	Discount Amount	Payable Amount		
<u>REF#MC9508</u>	TOLL CHARGES - 1/10/14	02/19/2014	02/19/2014	0.00	2 34		
Vendor Number	Vendor Filed As						Total Vendor Amount
<u>4152</u>	NORTH & EAST TEXAS COUNTY JUDGES & COMMISSIO						125 00
Payment Type	Payment Number						Payment Date Payment Amount
Check							02/20/2014 125 00
Payable Number	Description	Payable Date	Due Date	Discount Amount	Payable Amount		
<u>D00196</u>	ANNUAL MEMBERSHIP DUES	02/14/2014	02/14/2014	0 00	125 00		
Vendor Number	Vendor Filed As						Total Vendor Amount
<u>3634</u>	OIL PRICE INFORMATION SERVICE, LLC						1,162.80
Payment Type	Payment Number						Payment Date Payment Amount
Check							02/20/2014 1,162 80
Payable Number	Description	Payable Date	Due Date	Discount Amount	Payable Amount		
<u>197338</u>	1/2 COST OPIS WHOLESALE RACK REPORT	02/19/2014	02/19/2014	0 00	581 40		
<u>197338 R & B</u>	P O #57663 - 1/2 OF FEE- OPIS WHOLESALE RACK REP	02/14/2014	02/14/2014	0.00	581 40		
Vendor Number	Vendor Filed As						Total Vendor Amount
<u>2275</u>	OLMSTED-KIRK PAPER COMPANY						527 46
Payment Type	Payment Number						Payment Date Payment Amount
Check							02/20/2014 527 46
Payable Number	Description	Payable Date	Due Date	Discount Amount	Payable Amount		
<u>3243282</u>	MISC SUPPLIES FOR REPAIRS	02/19/2014	02/19/2014	0 00	185 71		
<u>3257758</u>	TISSUE, LINERS AND PINESOL	02/19/2014	02/19/2014	0 00	341 75		

Payment Register

Vendor Number	Vendor Filed As					Total Vendor Amount
<u>1949</u>	PANOLA COUNTY HISTORICAL & GENEALOGICAL ASSN					968 36
Payment Type	Payment Number			Payment Date	Payment Amount	
Check				02/20/2014	968 36	
Payable Number	Description	Payable Date	Due Date	Discount Amount	Payable Amount	
<u>2013 JUN-DEC</u>	REIMB FOR JUN-DEC 2013 UTILITY INVOICES	12/31/2013	12/31/2013	0 00	968 36	
<u>2554</u>	PANOLA COUNTY PLUMBING					5,182 27
Payment Type	Payment Number			Payment Date	Payment Amount	
Check				02/20/2014	5,182 27	
Payable Number	Description	Payable Date	Due Date	Discount Amount	Payable Amount	
<u>6827</u>	REPAIR TO STOPPED UP SEWER	02/13/2014	02/13/2014	0 00	250 00	
<u>6858</u>	NEW JAIL- INSTALLED NEW MIXER VALVE	02/13/2014	02/13/2014	0 00	4,596 62	
<u>6862</u>	DRAINED WATER LINE	02/13/2014	02/13/2014	0 00	75 00	
<u>6874</u>	REPLACED RUSTED FLANGE ON TOILET	02/13/2014	02/13/2014	0 00	260 65	
<u>2820</u>	PROSIGNS					30 00
Payment Type	Payment Number			Payment Date	Payment Amount	
Check				02/20/2014	30 00	
Payable Number	Description	Payable Date	Due Date	Discount Amount	Payable Amount	
<u>26343</u>	6 JAIL BANNERS	02/14/2014	02/14/2014	0 00	30 00	
<u>0333</u>	PUMP MASTERS, INC					258 00
Payment Type	Payment Number			Payment Date	Payment Amount	
Check				02/20/2014	258 00	
Payable Number	Description	Payable Date	Due Date	Discount Amount	Payable Amount	
<u>00102460</u>	P O #57670 - TECH AND MILEAGE FOR GAS PUMP	02/19/2014	02/19/2014	0.00	258 00	
<u>3066</u>	QT TECHNOLOGIES					995 00
Payment Type	Payment Number			Payment Date	Payment Amount	
Check				02/20/2014	995 00	
Payable Number	Description	Payable Date	Due Date	Discount Amount	Payable Amount	
<u>49900</u>	GOLD SERVICE AGREEMENT-WARRANTY-CC MACHINE	02/20/2014	02/20/2014	0.00	995.00	
<u>3229</u>	QUILL CORPORATION					142.49
Payment Type	Payment Number			Payment Date	Payment Amount	
Check				02/20/2014	142 49	
Payable Number	Description	Payable Date	Due Date	Discount Amount	Payable Amount	
<u>9260810</u>	HP q6470A BLACK TONER CARTRIDGE	02/13/2014	02/13/2014	0 00	142 49	
<u>3956</u>	REEDER'S AUTO REPAIR					370 00
Payment Type	Payment Number			Payment Date	Payment Amount	
Check				02/20/2014	370 00	
Payable Number	Description	Payable Date	Due Date	Discount Amount	Payable Amount	
<u>4626</u>	2009 FORD F150 REPAIRS	02/14/2014	02/14/2014	0 00	370 00	
<u>1304</u>	REINHART FOODSERVICE LOUISIANA					10,788 34
Payment Type	Payment Number			Payment Date	Payment Amount	
Check				02/20/2014	10,788 34	
Payable Number	Description	Payable Date	Due Date	Discount Amount	Payable Amount	
<u>888533 CM</u>	CREDIT MEMO FOR 11/23/2013	12/31/2013	12/31/2013	0 00	-20 52	
<u>892430 CM</u>	CREDIT MEMO 12/06/13	12/31/2013	12/31/2013	0 00	-22 24	
<u>898161 CM</u>	CREDIT MEMO 12/20/13	12/31/2013	12/31/2013	0 00	-29 56	
<u>909053</u>	1/22/14 FOOD FOR DETENTION CENTER	02/19/2014	02/19/2014	0.00	2,031 74	
<u>911503</u>	1/29/14 FOOD FOR DETENTION CENTER	02/19/2014	02/19/2014	0 00	2,849 22	

Payment Register

APPKT02997 - CC PC POOL 2-24-2014

912750	1/31/14 FOOD FOR DETENTION CENTER	02/19/2014	02/19/2014	0 00	284 10
914877	2/7/14 FOOD FOR DETENTION CENTER	02/19/2014	02/19/2014	0.00	2,955 00
916685	2/12/14 FOOD FOR DETENTION CENTER	02/19/2014	02/19/2014	0.00	2,740 60
Vendor Number	Vendor Filed As			Total Vendor Amount	
1217	RUSK-PANOLA SEXUAL ASSAULT RESPONSE TEAM			401.75	
Payment Type	Payment Number	Payment Date	Payment Amount		
Check		02/20/2014	401 75		
Payable Number	Description	Payable Date	Due Date	Discount Amount	Payable Amount
FEB 2014	SANE EXAM 12-16-13	12/31/2013	12/31/2013	0 00	401 75
Vendor Number	Vendor Filed As			Total Vendor Amount	
2599	SAM'S FAB & MACHINE, LLC			45 00	
Payment Type	Payment Number	Payment Date	Payment Amount		
Check		02/20/2014	45 00		
Payable Number	Description	Payable Date	Due Date	Discount Amount	Payable Amount
8678	P O #57602-FABRICATE STEEL BAR W/2 TAPPED HOLES	02/14/2014	02/14/2014	0 00	45 00
Vendor Number	Vendor Filed As			Total Vendor Amount	
1390	SC FUELS			22,771 82	
Payment Type	Payment Number	Payment Date	Payment Amount		
Check		02/20/2014	22,771.82		
Payable Number	Description	Payable Date	Due Date	Discount Amount	Payable Amount
2423184	FUEL PURCHASE FEB 6, 2014	02/19/2014	02/19/2014	0 00	22,771 82
Vendor Number	Vendor Filed As			Total Vendor Amount	
1780	SOUTHERN HEALTH PARTNERS, INC			7,375 00	
Payment Type	Payment Number	Payment Date	Payment Amount		
Check		02/20/2014	7,375 00		
Payable Number	Description	Payable Date	Due Date	Discount Amount	Payable Amount
BASE20881	HEALTH SERVICES MARCH 2014	02/19/2014	02/19/2014	0 00	7,375 00
Vendor Number	Vendor Filed As			Total Vendor Amount	
2505	SOUTHWESTERN ELECTRIC POWER COMPANY			1,512 51	
Payment Type	Payment Number	Payment Date	Payment Amount		
Check		02/20/2014	1,512 51		
Payable Number	Description	Payable Date	Due Date	Discount Amount	Payable Amount
02 10 14	ACCT#961-279-171-0-0 - 01/09/14 TO 02/07/14	02/20/2014	02/20/2014	0 00	1,512 51
Vendor Number	Vendor Filed As			Total Vendor Amount	
2521	SOUTHWESTERN ELECTRIC POWER COMPANY			2,474 09	
Payment Type	Payment Number	Payment Date	Payment Amount		
Check		02/20/2014	2,474 09		
Payable Number	Description	Payable Date	Due Date	Discount Amount	Payable Amount
02 10 14	ACCT#968-780-271-0-9 - 01/09/14 TO 02/07/14	02/19/2014	02/19/2014	0 00	2,474 09
Vendor Number	Vendor Filed As			Total Vendor Amount	
2576	SOUTHWESTERN ELECTRIC POWER COMPANY			1,439 07	
Payment Type	Payment Number	Payment Date	Payment Amount		
Check		02/20/2014	1,439 07		
Payable Number	Description	Payable Date	Due Date	Discount Amount	Payable Amount
02 10 14	ACCT#965-832-625-0-4 - 01/09/14 TO 02/07/14	02/19/2014	02/19/2014	0.00	1,439 07
Vendor Number	Vendor Filed As			Total Vendor Amount	
3869	SOUTHWESTERN ELECTRIC POWER COMPANY			3,020 70	
Payment Type	Payment Number	Payment Date	Payment Amount		
Check		02/20/2014	3,020.70		
Payable Number	Description	Payable Date	Due Date	Discount Amount	Payable Amount
02 10 14	ACCT#968-113-315-1-9 - 01/09/14 TO 02/07/14	02/20/2014	02/20/2014	0 00	3,020.70

Payment Register

Vendor Number 0580	Vendor Filed As STERLING SOLUTIONS, INC					Total Vendor Amount 700.00
Payment Type Check	Payment Number	Payment Date	Payment Amount			
		02/20/2014	700.00			
Payable Number 01802-040	Description VIMS MAINTS AGREEMENT-ONE YEAR	Payable Date 02/14/2014	Due Date 02/14/2014	Discount Amount 0.00	Payable Amount 700.00	
Vendor Number 3068	Vendor Filed As TAC					Total Vendor Amount 1,090.00
Payment Type Check	Payment Number	Payment Date	Payment Amount			
		02/20/2014	1,090.00			
Payable Number D0693	Description ANNUAL TAC DUES JAN 1, 2014 - DEC 31, 2014	Payable Date 02/14/2014	Due Date 02/14/2014	Discount Amount 0.00	Payable Amount 1,090.00	
Vendor Number 3873	Vendor Filed As TAYLOR FUNERAL HOME					Total Vendor Amount 441.00
Payment Type Check	Payment Number	Payment Date	Payment Amount			
		02/20/2014	441.00			
Payable Number 02_12_14	Description MARION O WHITESIDE, TRANS TO DALLAS M E	Payable Date 02/20/2014	Due Date 02/20/2014	Discount Amount 0.00	Payable Amount 441.00	
Vendor Number 2634	Vendor Filed As TDCAA					Total Vendor Amount 350.00
Payment Type Check	Payment Number	Payment Date	Payment Amount			
		02/20/2014	350.00			
Payable Number NIELSEN KATIE	Description REG FEE-KATIE NIELSEN - 4/28/14 TO 5/2/14	Payable Date 02/20/2014	Due Date 02/20/2014	Discount Amount 0.00	Payable Amount 350.00	
Vendor Number 0062	Vendor Filed As TEECO SAFETY, INC					Total Vendor Amount 749.26
Payment Type Check	Payment Number	Payment Date	Payment Amount			
		02/20/2014	749.26			
Payable Number 111964	Description FLASHLIGHTS, WTACH CAPS,MAGS,MACE CASE,LED REP.	Payable Date 12/31/2013	Due Date 12/31/2013	Discount Amount 0.00	Payable Amount 749.26	
Vendor Number 4141	Vendor Filed As TEXAS JAIL ASSOCIATION					Total Vendor Amount 30.00
Payment Type Check	Payment Number	Payment Date	Payment Amount			
		02/20/2014	30.00			
Payable Number FEB 2014	Description ALBERT GARZA 2014 MEMBERSHIP RENEWAL	Payable Date 02/19/2014	Due Date 02/19/2014	Discount Amount 0.00	Payable Amount 30.00	
Vendor Number 1560	Vendor Filed As TEXAS WILDLIFE DAMAGE MANAGEMENT FUND					Total Vendor Amount 2,700.00
Payment Type Check	Payment Number	Payment Date	Payment Amount			
		02/20/2014	2,700.00			
Payable Number 243088	Description JANUARY FIELD AGREEMENT SERVICES	Payable Date 02/14/2014	Due Date 02/14/2014	Discount Amount 0.00	Payable Amount 2,700.00	
Vendor Number 1797	Vendor Filed As THOMAS A. PRESSLY, III APMC					Total Vendor Amount 80.00
Payment Type Check	Payment Number	Payment Date	Payment Amount			
		02/20/2014	80.00			
Payable Number FILE #2026	Description MICHAEL D BARTON MED RECORDS	Payable Date 02/20/2014	Due Date 02/20/2014	Discount Amount 0.00	Payable Amount 80.00	
Vendor Number 1078	Vendor Filed As THOMSON REUTERS - WEST					Total Vendor Amount 1,538.80
Payment Type Check	Payment Number	Payment Date	Payment Amount			
		02/20/2014	1,538.80			
Payable Number 828911022	Description ACCT#1000629466 - JAN 2014 DATABASE CHARGES	Payable Date 02/13/2014	Due Date 02/13/2014	Discount Amount 0.00	Payable Amount 930.80	

Payment Register

APPKT02997 - CC PC POOL 2-24-2014

Vendor Number	Vendor Filed As	Payment Type	Payment Number	Payable Number	Description	Payable Date	Due Date	Discount Amount	Payable Amount	Total Vendor Amount
<u>829018163</u>	ACCT#1000629466 - FEB 2014 COMP LIBRARY SUB					02/20/2014	02/20/2014	0 00	608 00	
<u>1088</u>	THOMSON REUTERS - WEST	Check								600 08
<u>1592</u>	THOMSON REUTERS - WEST	Check								177 98
<u>1705</u>	TONI HUGHES	Check								119 00
<u>1029</u>	TRI-STATE FASTENERS & SUPPLY	Check								91 39
<u>0235</u>	TYSON FOODS, INC	Check								80 00
<u>0931</u>	UNIFIRST HOLDINGS, INC.	Check								39 00
<u>2695</u>	UPS	Check								7 17
<u>1365</u>	VERIZON WIRELESS	Check								1,468.78

Payment Register

Vendor Number	Vendor Filed As					Total Vendor Amount
<u>3890</u>	VERIZON WIRELESS					184 04
Payment Type	Payment Number				Payment Date	Payment Amount
Check					02/20/2014	184 04
Payable Number	Description	Payable Date	Due Date	Discount Amount	Payable Amount	
<u>9719133547</u>	ACCT#613439910-00001 - 01/26 TO 2/26	02/13/2014	02/13/2014	0 00	184.04	
<u>3909</u>	VERIZON WIRELESS					70 00
Payment Type	Payment Number				Payment Date	Payment Amount
Check					02/20/2014	70 00
Payable Number	Description	Payable Date	Due Date	Discount Amount	Payable Amount	
<u>9719113938</u>	ACCT#413284110-00001 - 01/27 - 02/26	02/13/2014	02/13/2014	0 00	70 00	
<u>1063</u>	VIP TECHNOLOGIES, INC					335 00
Payment Type	Payment Number				Payment Date	Payment Amount
Check					02/20/2014	335 00
Payable Number	Description	Payable Date	Due Date	Discount Amount	Payable Amount	
<u>35167</u>	2 NEW PHONES + SHIPPING	02/19/2014	02/19/2014	0 00	335 00	
<u>1286</u>	WILSON CULVERTS, INC					3,554 40
Payment Type	Payment Number				Payment Date	Payment Amount
Check					02/20/2014	3,554 40
Payable Number	Description	Payable Date	Due Date	Discount Amount	Payable Amount	
<u>67613</u>	P O #57250 - 2 STEEL CULVERTS	02/19/2014	02/19/2014	0 00	3,554 40	
<u>4213</u>	XEROX CORPORATION					526 22
Payment Type	Payment Number				Payment Date	Payment Amount
Check					02/20/2014	526 22
Payable Number	Description	Payable Date	Due Date	Discount Amount	Payable Amount	
<u>072357108</u>	CUST#713718914 - JANUARY 2014 LEASE	02/13/2014	02/13/2014	0 00	216 07	
<u>072357119</u>	CUST#716774617 - JANUARY 2014 LEASE	02/14/2014	02/14/2014	0 00	130 65	
<u>072357125</u>	CUST#719898124 - JANUARY 2014 LEASE	02/14/2014	02/14/2014	0 00	179 50	



Panola County, Texas

Payment Register

APPKT03001 - FEB 24, 2014 PROB

01 - Vendor Set 01

Bank: PROBATION DEPT POOL - PROBATION DEPARTMENTS POOLED CASH

Vendor Number	Vendor Filed As					Total Vendor Amount
<u>3433</u>	AMES COUNSELING AND FAMILY SERVICES					369 00
Payment Type	Payment Number			Payment Date	Payment Amount	
Check				02/21/2014	369 00	
Payable Number	Description	Payable Date	Due Date	Discount Amount	Payable Amount	
<u>11414LS</u>	1-14-14 LIFE SKILLS	02/21/2014	02/21/2014	0 00	85 00	
<u>12614LS</u>	1-21-14 LIFE SKILLS	02/21/2014	02/21/2014	0.00	85.00	
<u>2114LS</u>	1-28-14 LIFE SKILLS	02/21/2014	02/21/2014	0 00	85 00	
<u>2114PCR</u>	1-28-14 PCR	02/21/2014	02/21/2014	0.00	114 00	
Vendor Number	Vendor Filed As					Total Vendor Amount
<u>1338</u>	BUSINESS CARD					1 08
Payment Type	Payment Number			Payment Date	Payment Amount	
Check				02/21/2014	1.08	
Payable Number	Description	Payable Date	Due Date	Discount Amount	Payable Amount	
<u>4036478254721044-FC1252</u>	FINANCE CHARGE	02/21/2014	02/21/2014	0 00	1 08	
Vendor Number	Vendor Filed As					Total Vendor Amount
<u>4188</u>	HARRISON COUNTY					2,160 00
Payment Type	Payment Number			Payment Date	Payment Amount	
Check				02/21/2014	2,160 00	
Payable Number	Description	Payable Date	Due Date	Discount Amount	Payable Amount	
<u>1777</u>	KM-2 DAYS, RM 22 DAYS	02/21/2014	02/21/2014	0 00	2,160 00	
Vendor Number	Vendor Filed As					Total Vendor Amount
<u>1390</u>	SC FUELS					66 78
Payment Type	Payment Number			Payment Date	Payment Amount	
Check				02/21/2014	66 78	
Payable Number	Description	Payable Date	Due Date	Discount Amount	Payable Amount	
<u>2423184-JUVP</u>	FUEL PURCHASE	02/21/2014	02/21/2014	0.00	66 78	
Vendor Number	Vendor Filed As					Total Vendor Amount
<u>2441</u>	SHELBY COUNTY TREASURER					687 06
Payment Type	Payment Number			Payment Date	Payment Amount	
Check				02/21/2014	687.06	
Payable Number	Description	Payable Date	Due Date	Discount Amount	Payable Amount	
<u>1-2014</u>	JANUARY ROBERT CARLSEN DRUG CRT SAL REIMB	02/21/2014	02/21/2014	0 00	687 06	
Vendor Number	Vendor Filed As					Total Vendor Amount
<u>4426</u>	TEXAS CORRECTIONS ASSOCIATION					42 00
Payment Type	Payment Number			Payment Date	Payment Amount	
Check				02/21/2014	42 00	
Payable Number	Description	Payable Date	Due Date	Discount Amount	Payable Amount	
<u>1515-TCA252014TA</u>	TCA DUES 2014 TRACY ANDERSON #1515	02/21/2014	02/21/2014	0.00	42.00	
Vendor Number	Vendor Filed As					Total Vendor Amount
<u>4213</u>	XEROX CORPORATION					181 08
Payment Type	Payment Number			Payment Date	Payment Amount	
Check				02/21/2014	181.08	
Payable Number	Description	Payable Date	Due Date	Discount Amount	Payable Amount	
<u>072357124</u>	JANUARY 2014 BASE CHARGE	02/21/2014	02/21/2014	0.00	181 08	

PANOLA COUNTY, TEXAS

INVITATION TO BID

RETURN BID TO:

COUNTY JUDGE
PANOLA COUNTY COURTHOUSE, ROOM 216A
CARTHAGE, TEXAS 75633

The enclosed INVITATION TO BID (ITB) and accompanying SPECIFICATIONS AND BID SHEET are for your convenience in bidding the enclosed referenced service/products for Panola County

Sealed bids shall be received no later than:

9:00 A.M., MONDAY, FEBRUARY 24, 2014

MARK ENVELOPES

**"NEW ROOF ON PANOLA COUNTY SHERIFF'S
DEPARTMENT BUILDING COMPLEX"**

Bidder shall sign and date the bid. Bids which are not signed and dated can be rejected. Bids must be submitted on the enclosed bid sheets and must be in ink or typewritten.

Panola County appreciates your time and effort in preparing this bid. Please note that all bids must be received at the designated location by the deadline shown. Bids received after the deadline will not be considered for the award of the contract, and shall be considered void and unacceptable. Opening is scheduled to be held in Commissioners Courtroom, Panola County Courthouse, Carthage, Texas. You are invited to attend.

Any questions concerning this Invitation to Bid and specifications should be directed to Maintenance Superintendent, Fred Hightower, at (903) 693-0318.

Signature

INSTRUCTIONS/TERMS OF CONTRACT

By order of the Commissioners Court of Panola County, Texas, sealed bids will be received for:

**NEW ROOF ON PANOLA COUNTY SHERIFF'S
DEPARTMENT BUILDING COMPLEX**

IT IS UNDERSTOOD that the Commissioners Court of Panola County, Texas reserves the right to reject any or all bids to any or all products and/or services covered in this bid request and to waive informalities or defects in bids or to accept such bids as it shall deem to be in the best interests of Panola County.

BIDS MUST BE submitted on the bid forms included for that purpose in this packet. Bids shall be placed in separate sealed envelopes, with **each page manually signed by a person having the authority to bind the firm in a contract** and marked clearly on the outside as shown below.

SUBMISSION OF BIDS: Sealed bids shall be submitted to

**COUNTY JUDGE
PANOLA COUNTY COURTHOUSE, ROOM 216A
CARTHAGE, TEXAS 75633**

Not later than **9:00 a.m., Monday, February 24, 2014**

Mark Envelopes:

**"NEW ROOF ON PANOLA COUNTY SHERIFF'S
DEPARTMENT BUILDING COMPLEX"**

BIDS RECEIVED AFTER OPENING DATE AND TIME WILL NOT BE CONSIDERED

Signature

INVITATION TO BID
INSTRUCTIONS/TERMS OF CONTRACT

FUNDING: Funds for payment have been provided through the Panola County Budget adopted by the Commissioners' Court for Fiscal Year 2014.

LATE BIDS: Bids received after submission deadline will be considered void and unacceptable. Panola County is not responsible for lateness or non-delivery of mail, carrier, etc.

ALTERING BIDS: Bids cannot be altered or amended after submission deadline. Any interlineation, alteration or erasure made before opening time must be initialed by the signer of the bid, guaranteeing authenticity.

WITHDRAWAL OF BID: A bid may not be withdrawn or canceled by the bidder without the permission of Panola County for a period of ninety (90) days following the date designated for the receipt of bids, and bidder so agrees upon submission of their bid.

SALES TAX: Panola County is exempt by law from payment of Texas Sales Tax and Federal Excise Tax, therefore, the bid shall not include sales tax.

BID AWARD: Panola County reserves the right to award bids on the lump sum or unit price basis, whichever is in the best interest of Panola County.

CONTRACT: This bid, when properly accepted by Panola County, shall constitute a contract equally binding between the successful bidder and Panola County. No different or additional terms will become a part of this contract with the exception of Change Orders.

CHANGE ORDERS: No oral statement of any person shall modify or otherwise change, or affect the terms, conditions or specifications stated in the resulting contract. All change orders to the contract will be made in writing by the Panola County Judge.

DELIVERY: All delivery fees and freight or handling charges shall be as stated on the bid and contract forms section and if not so stated no such cost, fee or charge will be paid.

CONFLICT OF INTEREST: No public official shall have interest in this contract, in accordance with V.T.C.A., Local Government Code Title 5, Subtitle C, Chapter 171.

ETHICS: The bidder shall not offer or accept gifts or anything of value nor enter into any business arrangement with any employee, official or agent of Panola County.

EXCEPTIONS/SUBSTITUTIONS: All bids meeting the intent of this invitation to bid will be considered for award. Bidders taking exception to the specifications, or offering substitutions, shall state these exceptions in the section provided or by attachment as part

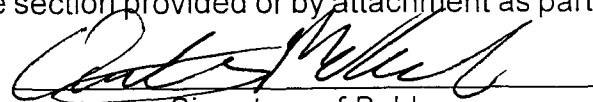

Signature of Bidder

of the bid. The absence of such a list shall indicate that the bidder has not taken exceptions and shall hold the bidder responsible to perform in strict accordance with the specifications of the invitation. Panola County Commissioners' Court reserves the right to accept any and all or none of the exception(s)/substitution(s) deemed to be in the best interest of the county.

DESCRIPTIONS: Any reference to model and/or make/maker used in bid specifications is descriptive, not restrictive. It is used to indicate the type and quality desired. Bids on items of like quality will be considered.

ADDENDA: Any interpretations, corrections or changes in this ITB and Specifications will be made by addenda. Sole issuing authority of addenda shall be vested in Panola County. Addenda will be mailed to all who are known to have received a copy of this ITB. Bidders shall acknowledge receipt of all addenda.

BIDS MUST COMPLY with all federal, state, county and local laws concerning these types of service.

DESIGN, STRENGTH, QUALITY of materials must conform to the highest standards of manufacturing practice.

MINIMUM STANDARDS FOR RESPONSIBLE PROSPECTIVE BIDDERS: A prospective bidder must affirmatively demonstrate bidder's responsibility. A prospective bidder must meet the following requirements:

1. have adequate financial resources, or the ability to obtain such resources as required,
2. be able to comply with the required or proposed delivery schedule;
3. have a satisfactory record of performance;
4. have a satisfactory record of integrity and ethics,
5. be otherwise qualified and eligible to receive an award.

Panola County may request any other information sufficient to determine bidder's ability to meet these minimum standards listed above.

REFERENCES: Panola County may request bidder to supply a list of at least three (3) references where like services/products have been supplied by their firm.

BIDDER SHALL PROVIDE with this bid response, all documentation required by this ITB. Failure to provide this information may result in rejection of bid.

SUCCESSFUL BIDDER SHALL defend, indemnify, and save harmless Panola County and all its officers, agents and employees from all suits, actions, or other claims of any character, name and description brought for or on account of any injuries or damages

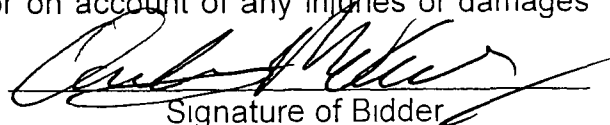
Signature of Bidder

received or sustained by any person, persons or property on account of any negligent act or fault of the successful bidder, or of any agent, employee, subcontractor or supplier in the execution of, or performance under, any contract which may result from bid award. Successful bidder indemnifies and will indemnify and save harmless Panola County from liability, claim or demand on their part, agents, servants, customers, and/or employees whether such liability, claim or demand arise from event or casualty happening or within the occupied premises themselves or happening upon or in any of the halls, elevators, entrances, stairways or approaches of or to the facilities within which the occupied premises are located. Successful bidder shall pay any judgment costs which may be obtained against Panola County growing out of such injury or damages.

WAGES: Successful bidder shall pay or cause to be paid, without cost or expense to Panola County, all Social Security, Unemployment and Federal Income Withholding Taxes of all such employees and all such employees shall be paid wages and benefits as required by Federal and/or State law.

TERMINATION OF CONTRACT: This contract shall remain in effect until contract expires, delivery and acceptance of products and/or performance of services ordered or terminated by either party with a thirty (30) days written notice prior to any cancellation. The successful bidder must state therein the reasons for such cancellation. Panola County reserves the right to award canceled contract to the next lowest and best bidder as it deems to be in the best interest of the county.

TERMINATION FOR DEFAULT: Panola County reserves the right to enforce the performance of this contract in any manner prescribed by law or deemed to be in the best interest of the county in the event of breach or default of this contract. Panola County reserves the right to terminate the contract immediately in the event the successful bidder fails to:

1. meet schedules;
2. defaults in the payment of any fees; or
3. otherwise perform in accordance with these specifications.

Breach of contract or default authorizes the county to exercise any or all of the following rights:

1. Panola County may take possession of the assigned premises and any fees accrued or becoming due to date;
2. Panola County may take possession of all goods, fixtures and materials of successful bidder therein and may foreclose its lien against such personal property, applying the proceeds toward fees due or thereafter becoming due.

In the event the successful bidder shall fail to perform, keep or observe any of the terms

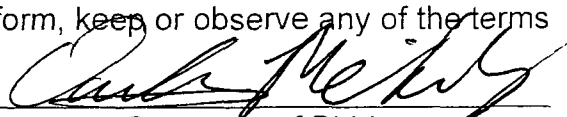
Signature of Bidder

and conditions to be performed, kept or observed, Panola County shall give the successful bidder written notice of such default; and in the event said default is not remedied to the satisfaction and approval of the county within two (2) working days of receipt of such notice by the successful bidder, default will be declared and all the successful bidder's rights shall terminate.

Bidder, in submitting this bid, agrees Panola County shall not be liable to prosecution for damages in the event that the county declared the bidder in default

NOTICE. Any notices provided by this bid (or required by law) to be given to the successful bidder by Panola County shall be conclusively deemed to have been given and received on the next day after such written notice has been deposited in the mail in Carthage, Texas, by Registered or Certified Mail with sufficient postage affixed thereto, addressed to the successful bidder at the address so provided; provided this shall not prevent the giving of actual notice in any other manner.

PATENTS/COPYRIGHTS: The successful bidder agrees to protect Panola County from claims involving infringement of patents and/or copyrights.

CONTRACT ADMINISTRATION: Panola County may appoint a contract administrator with designated responsibility to ensure compliance with contract requirements. The contract administrator will serve as liaison between Panola County and the successful bidder

PURCHASE ORDER A purchase order(s) shall be generated by Panola County to the successful bidder. The purchase order number must appear on all itemized invoices and packing slips. Panola County will not be held responsible for any orders placed/delivered without a valid current purchase order number.

INVOICES shall show (a) name and address of successful bidder; (b) county purchase order number; and (c) descriptive information as to the item(s) delivered.

PAYMENT will be made upon receipt and acceptance by the county of item(s) ordered and receipt of a valid invoice, in accordance with State of Texas Prompt Payment Act, V.T.C.S. Article 601f. Successful bidder is required to pay subcontractors within ten (10) days.

ITEMS supplied under this contract shall be subject to Panola County's approval. Items found defective or not meeting specifications shall be picked up and replaced by the successful bidder at no expense to the county. If item is not picked up within one (1) week after notification, the item will become a donation to the county for disposition.

SAMPLES: When requested, samples shall be furnished free of expense to Panola County

WARRANTY Successful bidder shall warrant that all items/services shall conform to the

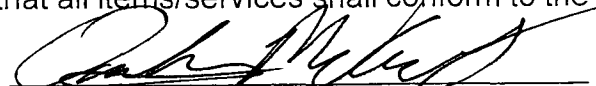

Signature of Bidder

proposed specifications and/or all warranties as stated in the Uniform Commercial Code and be free from all defects in material, workmanship and title.

REMEDIES: The successful bidder and Panola County agree that both parties have all rights, duties, and remedies available as stated in the Uniform Commercial Code

VENUE. This agreement will be governed and construed according to the laws of the State of Texas. This agreement is performable in Panola County, Texas

ASSIGNMENT. The successful bidder shall not sell, assign, transfer or convey this contract, in whole or in part, without the prior written consent of Panola County.

SILENCE OF SPECIFICATIONS: The apparent silence of these specifications as to any detail or to the apparent omission from it of a detailed description concerning any point, shall be regarded as meaning that only the best commercial practices are to prevail. All interpretations of these specifications shall be made on the basis of this statement.

Each insurance policy to be furnished by successful bidder shall include, by endorsement to the policy, a statement that a notice shall be given to Panola County by certified mail thirty (30) days prior to cancellation or upon any material change in coverage.

ANY VENDOR THAT CONDUCTS BUSINESS WITH PANOLA COUNTY, WHETHER IT IS FOR GOODS AND/OR SERVICES, MUST MAINTAIN LAWFUL WORKER'S COMPENSATION COVERAGE REQUIREMENTS AND ADEQUATE LIABILITY LIMITATIONS.

ANY QUESTIONS concerning this INVITATION TO BID AND SPECIFICATIONS should be directed to Panola County Courthouse Maintenance Superintendent Fred Hightower at (903) 693-0318



Signature of Bidder

County of Panola
110 S Sycamore
Carthage, TX 75633

January 27, 2014
(903) 693-0391
(903) 693-2726 (fax)

Request for bids for the following work to be completed on the Sheriff's Department Building Complex. (See Attachment "A")

Subject: New 60 mil white TPO membrane roof system by GAF or equal (See Attachments "B" & "C" for system, walls and drains special requirements)

Basic Scope of Work:

1. Transition brick wall 148' x 7' tall to be cleaned thoroughly, all cracks 1/16" or greater injected with Geocel clear caulking before applying Prosoco clear waterproofing in 2 coats per manufacturer's instructions.
2. Reference Attachment "A", blue shade- Adjoining brick wall to main courthouse. Use same Prosoco waterproofing specification plus see Attachment "C" for lower base flashing detail at weeps.
3. Perform infrared scan over entire roof with special moisture scan report. Any moisture infested area to be marked for removal.
4. Remove all gravel to smooth and fully prepared surface free of any existing gravel.
5. Cut and remove all base flashing at walls / curbs to smooth surfaces.
6. Remove all wet areas (if any) revealed by infrared scan to deck and install 3.5" leveling ISO insulation fill and mechanically fasten to deck as required (See unit cost schedule for extra cost for this work).
7. Adhere 1/2" HD ISO premium cover / protection board over all prepared surfaces using low rise urethane foam adhesive. Use I-90 attachment pattern for fastening pattern.
8. Install 60 mil white TPO membrane roofing by GAF or equal as a fully adhered system installation. All roof system with all details at all conditions must be approved system details for the manufacturer's 20 year system NDL labor and material non-prorated warranty.
9. See Attachment "B" & "C" for all wall and roof drain details.
10. Stone coping to be cleaned and sealed using Prosoco clear waterproofing. Check all caulk joints and touch up, if needed.
11. Use Dura-Blok stands to support all heavy equipment that sits on the roof. Contractor's preference for conduit or small lines. Must be approved by manufacturer (No wood please).
12. 20 year system Diamond Pledge NDL labor and warranty from manufacturer or equal

Price \$ 125,600.00 One hundred twenty five thousand six hundred & 00/100

Notes:

- 1 Certificates of insurance required for both workman's compensation and general liability
- 2 OSHA safety set up and practices required
3. Clean up daily and end of job
4. Courtyard to be protected, any damage must be repaired properly
- 5 Manufacturer's inspections mandatory with written reports for system acceptance for warranty validation for coating and membrane roofing systems

Extra Cost for Unit Cost Schedule:

1. Remove and replace wet areas revealed by infrared scan and add leveling ISO insulation. **Price :** 2.00 per square foot
2. Remove and replace decking. **Price:** \$5.00 per square foot
3. Restoration of rusty decking, wire brushing, Ospho and red ox primer.
Price: \$2.50 per square foot

BID**NEW ROOF ON PANOLA COUNTY SHERIFF'S
DEPARTMENT BUILDING COMPLEX**

TO THE COMMISSIONERS' COURT OF PANOLA COUNTY, TEXAS FOR FURNISHING AND DELIVERING TO PANOLA COUNTY, TEXAS FOR USE BY PANOLA COUNTY, IN ACCORDANCE WITH THE FOREGOING SPECIFICATIONS.

The undersigned, as bidder, declares that the only person or persons interested in this bid as principals are those named herein; that this bid is made without collusion with any other person, firm or corporation; and that I (we) have carefully examined the advertisements, instructions to bidders, specifications, and condition of payment. It is understood that the Court reserves the right to accept or reject any and/or all bids. I/we understand that the bid should include delivery to the Panola County Courthouse in Carthage, Texas.

Total Cost for Basic Scope of Work: \$ 125,600.00

Extras:

**Remove and replace wet areas
revealed by infrared scan and add
leveling ISO insulation (per square foot)** \$ 2.00

**Remove and replace decking
(per square foot)** \$ 5.00

**Restoration of rusty decking, wire
brushing, Ospho and red ox primer
(per square foot)** \$ 2.50

Exceptions to specifications: None

NOTE: ANY VENDOR THAT CONDUCTS BUSINESS WITH PANOLA COUNTY, WHETHER IT IS FOR GOODS AND/OR SERVICES, MUST MAINTAIN LAWFUL WORKER'S COMPENSATION COVERAGE REQUIREMENTS AND ADEQUATE LIABILITY LIMITATIONS.

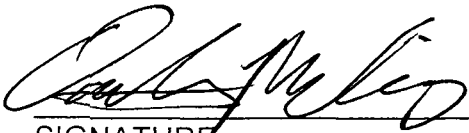
SIGNATURE

Curtis-McKinley Roofing & Sheet Metal, Inc.
COMPANY NAME

PO Box 3105
ADDRESS

Longview TX 75606
CITY STATE ZIP

903-757-7402
TELEPHONE NUMBER

2/24/14
DATE

ACCEPTED.



COUNTY JUDGE

2-24-14
DATE

Anthony@curtis.mckinley.com
David McK@curtis.mckinley.com

Attachment "A"

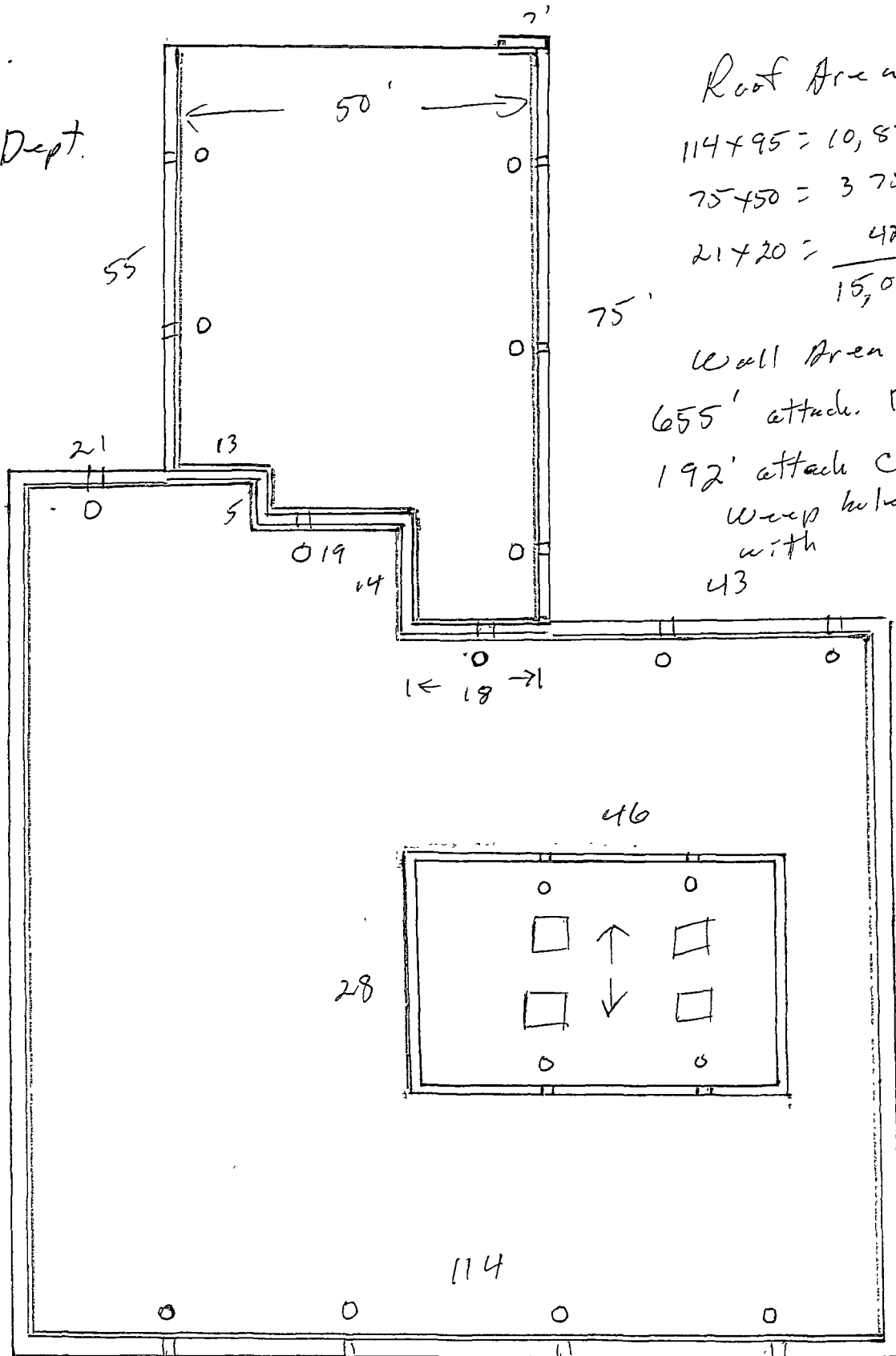
Pondera Co.
 Sheriff's Dept.
 Complex



Roof Area
 $114 \times 95 = 10,830$
 $75 \times 50 = 3,750$
 $21 \times 20 = \frac{420}{15,000 \text{ sq ft}}$

Wall Area
 655' attach. B
 192' attach C with
 weep holes to deal
 with
 43

No work

Re-roof

[Handwritten signature]

PANOLA COUNTY SHERIFFS' DEPT
WALL DETAIL
ATTACHMENT "B"

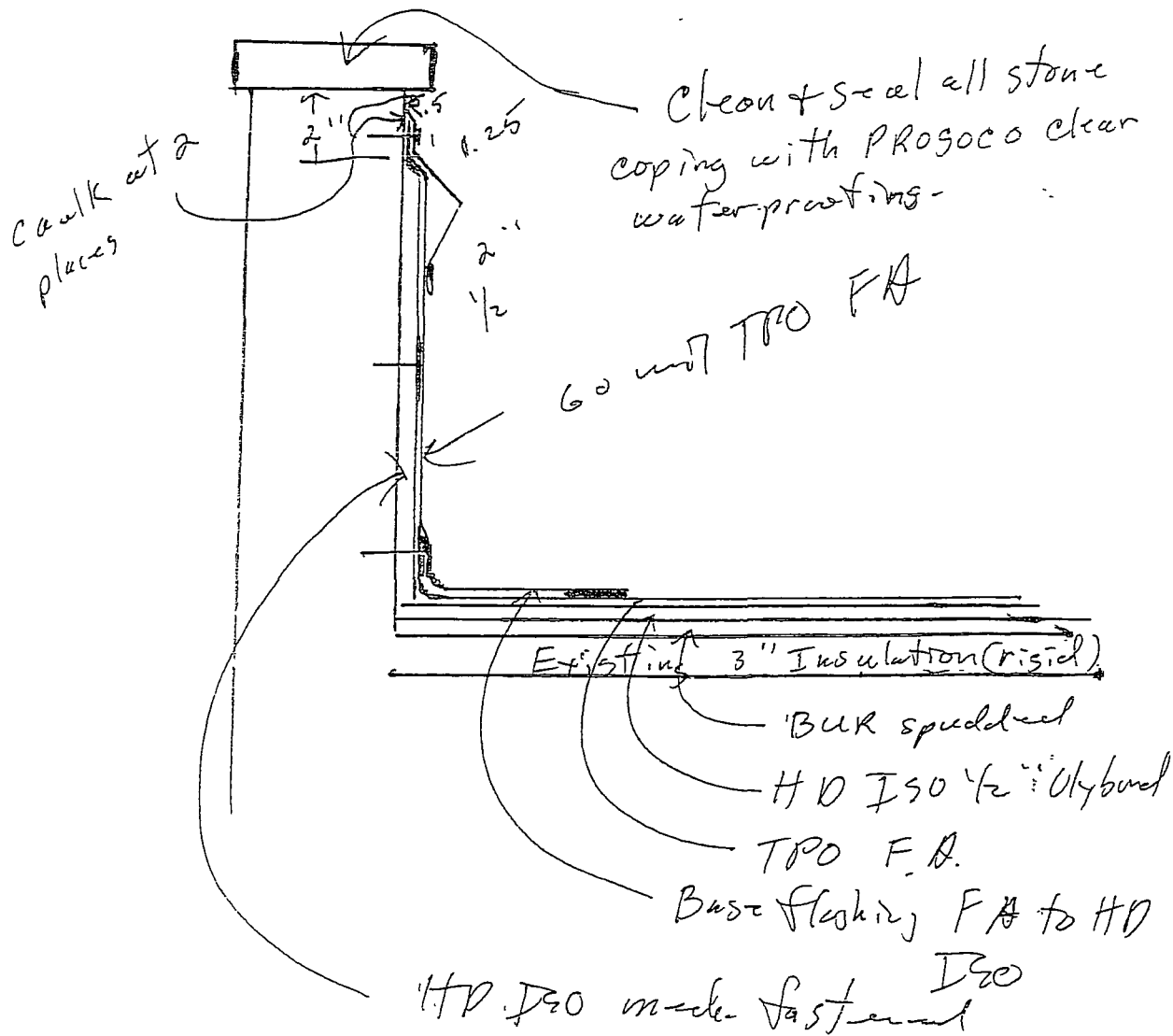

Attachment "C"

Penola Co.
SHERIFF'S DEPT

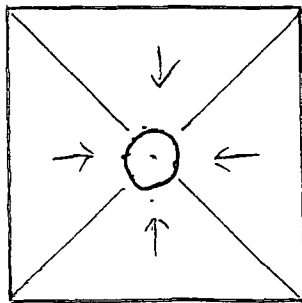
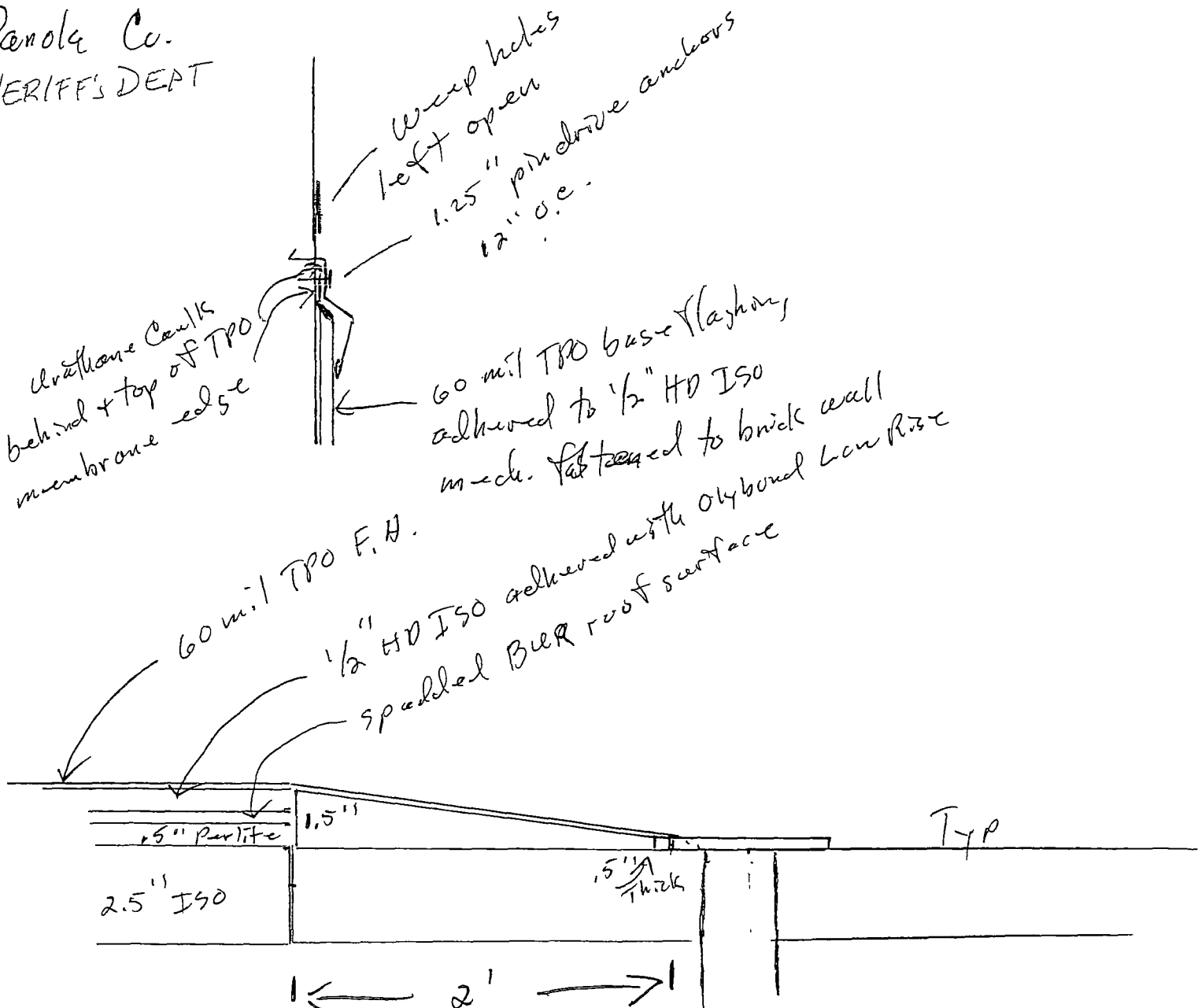

Drain Sumps 2' x 2'
1/2" tapered ISO
1/2" min > 1.5' x 2'

[Handwritten signature]



AIA Document A305

Contractor's Qualification Statement

1986 EDITION

This form is approved and recommended by The American Institute of Architects (AIA) and The Associated General Contractors of America (AGC) for use in evaluating the qualifications of contractors. No endorsement of the submitting party or verification of the information is made by the AIA or AGC.

The Undersigned certifies under oath that the information provided herein is true and sufficiently complete so as not to be misleading.

SUBMITTED TO
ADDRESS

SUBMITTED BY	Curtis-McKinley Roofing & Sheet Metal, Inc.	Corporation	<input checked="" type="checkbox"/>
NAME	David McKinley, President	Partnership	<input type="checkbox"/>
ADDRESS	PO Box 3105, Longview, TX 75606	Individual	<input type="checkbox"/>
PRINCIPAL OFFICE	4515 Alpine Rd., Longview, TX 75605	Joint Venture	<input type="checkbox"/>
		Other	<input type="checkbox"/>

NAME OF PROJECT (if applicable)

TYPE OF WORK (file separate form for each Classification of Work)

_____ General Construction	_____ HVAC
_____ Plumbing	_____ Electrical
<u>X</u> Other <u>Roofing and Sheet Metal</u>	
(please specify)	

Copyright 1964, 1969, 1979, ©1986 by The American Institute of Architects, 1735 New York Avenue, N.W., Washington, D.C. 20006. Reproduction of the material herein or substantial quotation of its provisions without written permission of the AIA violates the copyright laws of the United States and will be subject to legal prosecution.

1. ORGANIZATION

1 1 How many years has your organization been in business as a Contractor?

28 years

1 2 How many years has your organization been in business under its present business name?

28 years

1 2 1 Under what other or former names has your organization operated?

1 3 If your organization is a corporation, answer the following:

1 3 1 Date of incorporation 1/24/86

1 3 2 State of incorporation Texas

1 3 3 President's name David McKinley

1 3 4 Vice-president's name(s) Anthony McKinley

1 3 5 Secretary's name David McKinley

1 3 6 Treasurer's name Nancy McKinley

1 4 If your organization is a partnership, answer the following N/A

1 4 1 Date of organization

1 4 2 Type of partnership (if applicable)

1 4 3 Name(s) of general partner(s)

1 5 If your organization is individually owned, answer the following N/A

1 5 1 Date of organization

1 5 2 Name of owner

- 1 6 If the form of your organization is other than those listed above, describe it and name the principals

N/A

2. LICENSING

- 2 1 List jurisdictions and trade categories in which your organization is legally qualified to do business, and indicate registration or license numbers, if applicable

Texas
 Oklahoma
 Louisiana - Contractor's License #25713
 Arkansas - Contractor's License #0167670406
 Mississippi - Contractor's License #083-78132-8

- 2 2 List jurisdictions in which your organization's partnership or trade name is filed.

Texas
 Louisiana
 Arkansas
 Mississippi

3. EXPERIENCE

- 3 1 List the categories of work that your organization normally performs with its own forces

Roofing and Sheet Metal Work

- 3 2 Claims and Suits (If the answer to any of the questions below is yes, please attach details)

3 2 1 Has your organization ever failed to complete any work awarded to it?

No

3 2 2 Are there any judgments, claims, arbitration proceedings or suits pending or outstanding against your organization or its officers?

No

3 2 3 Has your organization filed any law suits or requested arbitration with regard to construction contracts within the last five years?

No

- 3 3 Within the last five years, has any officer or principal of your organization ever been an officer or principal of another organization when it failed to complete a construction contract? (If the answer is yes, please attach details) No

- 3.4 On a separate sheet, list major construction projects your organization has in progress, giving the name of project, owner, architect, contract amount, percent complete and scheduled completion date
- 3.4.1 State total worth of work in progress and under contract
- 3.5 On a separate sheet, list the major projects your organization has completed in the past five years, giving the name of project, owner, architect, contract amount, date of completion and percentage of the cost of the work performed with your own forces.
- 3.5.1 State average annual amount of construction work performed during the past five years
- 3.6 On a separate sheet, list the construction experience and present commitments of the key individuals of your organization

4. REFERENCES

4.1 Trade References. *See Attachment "B" for additional references

Amtech Roofing Consultants, Inc. 14107 Haymeadow Dallas, TX 75240	Mike Blanchette	800-828-2465
---	-----------------	--------------

Siplast 1000 E. Rochelle Blvd. Irving, TX 75062-3940	John Dillard	800-922-8800
--	--------------	--------------

US Army Corps of Engineers PO Box 59 Louisville, KY 40201-0059	Olan "Bud" Lewis	903-240-2314
--	------------------	--------------

4.2 Bank References

Community Bank PO Box 2232 Longview, TX 75606-2232	Kathy Tittle	903-232-1402
--	--------------	--------------

4.3 Surety

4.3.1 Name of bonding company

AON Risk Services 2711 N. Haskell, Ste. 800 Dallas, TX 75204	CNA Insurance Company PO Box 651211 Dallas, TX 75285
--	--

4.3.2 Name and address of agent

Don Cornell - 214-989-2604 AAON Risk Services 2711 N. Haskell, Ste. 800 Dallas, TX 75602	David McWhorter Gans & Smith Insurance PO Box 2869 Longview, TX 75606	903-757-4601
---	--	--------------

5. FINANCING

5.1 Financial Statement *Available upon consideration for award of contract

5 1 1 Attach a financial statement, preferably audited, including your organization's latest balance sheet and income statement showing the following items

Current Assets (e g , cash, joint venture accounts, accounts receivable, notes receivable, accrued income, deposits, materials inventory and prepaid expenses),

Net Fixed Assets,

Other Assets,

Current Liabilities (e g., accounts payable, notes payable, accrued expenses, provision for income taxes, advances, accrued salaries and accrued payroll taxes),

Other Liabilities (e g , capital, capital stock, authorized and outstanding shares par values, earned surplus and retained earnings)

5 1 2 Name and address of firm preparing ~~attached~~ financial statement, and date thereof
John Ussery, CPA 903-295-8017 Dishman, Goodman, Ussery,
Gourcier & Gadt

5 1 3 Is the attached financial statement for the identical organization named on page one?

CPA - address - 2020 Bill Owens Parkway, Ste. 160
Longview, TX 75604

5 1 4 If not, explain the relationship and financial responsibility of the organization whose financial statement is provided (e g., parent-subsiidiary)

5 2 Will the organization whose financial statement is attached act as guarantor of the contract for construction?

6. SIGNATURE

61

Name of Organization Curtis-McKinley Roofing & Sheet Metal, Inc.

By

[Handwritten Signature]

David McKinley

Title

President

62

Mr. David McKinley, President of Curtis-McKinley Roofing & Sheet Metal, Inc. being duly sworn deposes and says that the information provided herein is true and sufficiently complete so as not to be misleading

Subscribed and sworn before me this 3rd day of January, 2014

Notary Public

My Commission Expires 9-18-15



CAUTION: You should sign an original AIA document which has this caution printed in red. An original assures that changes will not be obscured as may occur when documents are reproduced.



CERTIFICATE OF LIABILITY INSURANCE

DATE (MM/DD/YYYY)
4/26/2013

THIS CERTIFICATE IS ISSUED AS A MATTER OF INFORMATION ONLY AND CONFERS NO RIGHTS UPON THE CERTIFICATE HOLDER. THIS CERTIFICATE DOES NOT AFFIRMATIVELY OR NEGATIVELY AMEND, EXTEND OR ALTER THE COVERAGE AFFORDED BY THE POLICIES BELOW. THIS CERTIFICATE OF INSURANCE DOES NOT CONSTITUTE A CONTRACT BETWEEN THE ISSUING INSURER(S), AUTHORIZED REPRESENTATIVE OR PRODUCER, AND THE CERTIFICATE HOLDER.

IMPORTANT: If the certificate holder is an ADDITIONAL INSURED, the policy(ies) must be endorsed. If SUBROGATION IS WAIVED, subject to the terms and conditions of the policy, certain policies may require an endorsement. A statement on this certificate does not confer rights to the certificate holder in lieu of such endorsement(s).

PRODUCER Gans & Smith Insurance Agency, Inc. P.O Box 2869 Longview TX 75606	CONTACT NAME Deborah Latting, ACSR PHONE (A/C No. Ext): (903) 757-4601 E-MAIL ADDRESS dlatting@gans-smith.com	FAX (A/C. No): (903) 753-0782
	INSURER(S) AFFORDING COVERAGE	
INSURED Curtis-McKinley Roofing & Sheet Metal Inc P O Box 3105 Longview TX 75606	INSURER A American Casualty Co of Reading 20427C	NAIC #
	INSURER B Transportation Ins Co (CNA) 20494C	
	INSURER C Continental Casualty Co (CNA) 20443C	
	INSURER D	
	INSURER E	
	INSURER F	

COVERAGES CERTIFICATE NUMBER: CL1342600763 REVISION NUMBER:

THIS IS TO CERTIFY THAT THE POLICIES OF INSURANCE LISTED BELOW HAVE BEEN ISSUED TO THE INSURED NAMED ABOVE FOR THE POLICY PERIOD INDICATED NOTWITHSTANDING ANY REQUIREMENT, TERM OR CONDITION OF ANY CONTRACT OR OTHER DOCUMENT WITH RESPECT TO WHICH THIS CERTIFICATE MAY BE ISSUED OR MAY PERTAIN, THE INSURANCE AFFORDED BY THE POLICIES DESCRIBED HEREIN IS SUBJECT TO ALL THE TERMS, EXCLUSIONS AND CONDITIONS OF SUCH POLICIES. LIMITS SHOWN MAY HAVE BEEN REDUCED BY PAID CLAIMS

INSR LTR	TYPE OF INSURANCE	ADDL INSR	SUBR WVD	POLICY NUMBER	POLICY EFF (MM/DD/YYYY)	POLICY EXP (MM/DD/YYYY)	LIMITS
A	GENERAL LIABILITY			1015890147	5/1/2013	5/1/2014	EACH OCCURRENCE \$ 1,000,000
	<input checked="" type="checkbox"/> COMMERCIAL GENERAL LIABILITY						DAMAGE TO RENTED PREMISES (Ea occurrence) \$ 100,000
	<input type="checkbox"/> CLAIMS-MADE <input checked="" type="checkbox"/> OCCUR						MED EXP (Any one person) \$ 5,000
							PERSONAL & ADV INJURY \$ 1,000,000
							GENERAL AGGREGATE \$ 2,000,000
							PRODUCTS - COMP/OP AGG \$ 2,000,000
							\$
B	AUTOMOBILE LIABILITY			1015886521	5/1/2013	5/1/2014	COMBINED SINGLE LIMIT (Ea accident) \$ 1,000,000
	<input checked="" type="checkbox"/> ANY AUTO						BODILY INJURY (Per person) \$
	<input type="checkbox"/> ALL OWNED AUTOS	<input type="checkbox"/> SCHEDULED AUTOS					BODILY INJURY (Per accident) \$
	<input type="checkbox"/> HIRED AUTOS	<input type="checkbox"/> NON-OWNED AUTOS					PROPERTY DAMAGE (Per accident) \$
							Blanket Add'l Insured-Lessor \$
							\$
C	<input checked="" type="checkbox"/> UMBRELLA LIAB <input checked="" type="checkbox"/> OCCUR			2083102194	5/1/2013	5/1/2014	EACH OCCURRENCE \$ 1,000,000
	<input type="checkbox"/> EXCESS LIAB <input type="checkbox"/> CLAIMS-MADE						AGGREGATE \$ 1,000,000
	<input type="checkbox"/> DED <input checked="" type="checkbox"/> RETENTION \$ 10,000						\$
C	WORKERS COMPENSATION AND EMPLOYERS' LIABILITY			121551710	5/1/2013	5/1/2014	<input checked="" type="checkbox"/> WC STATUTORY LIMITS <input type="checkbox"/> OTHER
	ANY PROPRIETOR/PARTNER/EXECUTIVE OFFICER/MEMBER EXCLUDED? (Mandatory in NH)	<input type="checkbox"/> Y <input type="checkbox"/> N	N/A				E L EACH ACCIDENT \$ 1,000,000
	If yes, describe under DESCRIPTION OF OPERATIONS below						E L DISEASE - EA EMPLOYEE \$ 1,000,000
							E L DISEASE - POLICY LIMIT \$ 1,000,000

DESCRIPTION OF OPERATIONS / LOCATIONS / VEHICLES (Attach ACORD 101, Additional Remarks Schedule, if more space is required)

CERTIFICATE HOLDER **CANCELLATION**

FOR INFORMATION & BIDDING PURPOSES ONLY	SHOULD ANY OF THE ABOVE DESCRIBED POLICIES BE CANCELLED BEFORE THE EXPIRATION DATE THEREOF, NOTICE WILL BE DELIVERED IN ACCORDANCE WITH THE POLICY PROVISIONS.
	AUTHORIZED REPRESENTATIVE D McWhorter CIC/DJL <i>David J McWhorter</i>

**SEXUALLY ORIENTED BUSINESS
ORDER, PERMIT AND LICENSE APPEAL
BOARD APPOINTMENTS**

We, the Commissioners' Court of Panola County, Texas meeting in Special Session this 24th day of February, 2014 do hereby appoint the following persons to a one (1) year term on the **SEXUALLY ORIENTED BUSINESS ORDER, PERMIT AND LICENSE APPEAL BOARD**

- 1. Jim Stevens**
- 2. Pastor Carl Anderson**
- 3. Ms. Fatha Burchette**
- 4. Reverend Steve Jackson**
- 5. Reverend Mervyn Scott**

Said one (1) year terms will commence February 27, 2014 and end February 27, 2015.

PASSED this 24th day of February, 2014 in Open Court.

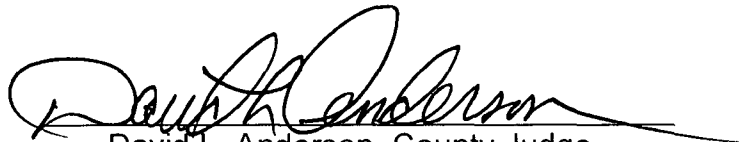
David L. Anderson, County Judge

RESOLUTION

WHEREAS, it is hereby declared that Panola County has adopted Citizen Complaint Procedures regarding its Texas Community Development Block Grant Programs; and

WHEREAS, it is further declared that establishment of such procedures requires the designation of a person to receive and respond to such complaints; and

WHEREAS, it is the intent of Panola County to investigate complaints about proposed TxCDBG activities or implementation of past TxCDBG assisted activities.

NOW, THEREFORE, BE IT RESOLVED BY THE COMMISSIONERS COURT OF PANOLA COUNTY, TEXAS;

1. That the County adopt the attached Citizen Complaint Procedures for the Texas Community Development Block Grant Program.
2. That the County designates the Administrative Assistant to the County Judge as the Community Development Coordinator.
3. That the County directs the Community Development Coordinator to receive and respond to complaints.

Passed and approved this 24th day of February, 2014.

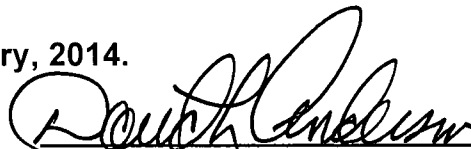
David L. Anderson, County Judge

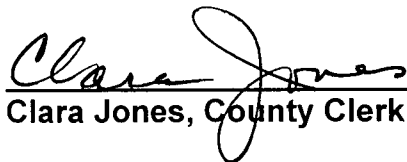
Clara Jones, County Clerk

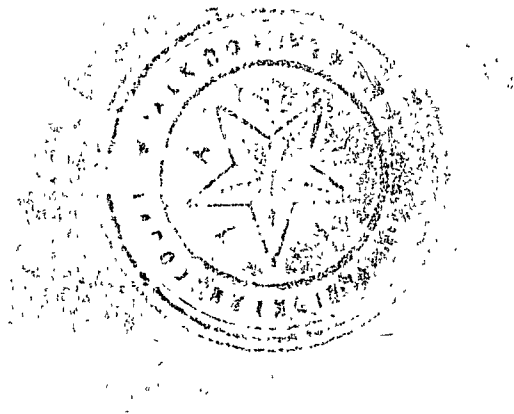

PROCLAMATION

WHEREAS, Title VIII of the Civil Rights Act of 1968, as amended, prohibits discrimination in housing and declares it a national policy to provide, within constitutional limits, for fair housing in the Unites States; and

WHEREAS, The principle of Fair Housing is not only national law and national policy, but a fundamental human concept and entitlement for all Americans, and

WHEREAS, the National Fair Housing Law, during the month of April, provides an opportunity for all Americans to recognize that complete success in the goal of equal housing opportunity can only be accomplished with the help and cooperation of all Americans.

NOW, THEREFORE, WE, the Commissioners' Court of Panola County, Texas do hereby proclaim the month of April, 2014 to be

“FAIR HOUSING MONTH”

in Panola County, and hereby urge all local officials, public and private organizations, and citizens of Panola County to become aware of and support the Fair Housing law

DONE IN OPEN COURT this 24th day of February, 2014.

County Judge

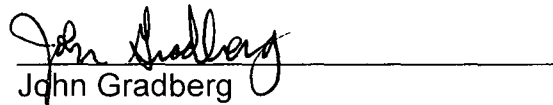

Ronnie LaGrone
Commissioner, Precinct 1

John Gradberg
Commissioner, Precinct 2

Frank R. Langley, Jr.
Commissioner, Precinct 3

Dale LaGrone
Commissioner, Precinct 4

ATTEST:

County Clerk Clara Jones



State of Texas
County of PANOLA

1. This contract is by and between East Texas Council of Governments (ETCOG) and PANOLA COUNTY (hereinafter referred to as the County), and is in aid of Governor's Office, Criminal Justice Division (CJD) Grant No. SF-25417-01, titled Regional Evaluation Services for Juveniles. It is understood by all parties that payment obligations created by this contract are conditioned upon the availability of State or Federal funds appropriated or allocated for the payment of such obligations. The term of this contract shall commence on September 1, 2013, and shall end on August 31, 2014, unless extended or terminated as otherwise provided for in this contract.
2. ETCOG is responsible for closely monitoring the County and the all terms and conditions of the grant. The County agrees to fully cooperate in the monitoring process.
3. Requirements of the *Uniform Grant and Contract Management Standards (UGCMS)* promulgated pursuant to Section 783, of the Government Code are adopted by reference as part of this contract, including the contract provision as in Section 36, Common Rule of OMB, of the above standards. ETCOG shall keep all project records.
4. The County will furnish the following:
 - a. Invoices for services rendered.
 - b. Information for progress reports.
5. The County will comply with the following:
 - a. **Return this executed contract to ETCOG by February 28, 2014, or forfeit County's funding allocation. ETCOG staff shall redistribute any forfeited funds to participating counties.**
 - b. Special Limitations (Attachment A to Contract).
 - c. Submission of signed Payment Voucher (Attachment B to Contract), copy of bill(s) for psychological and/or psychiatric services purchased, and Certification form to request reimbursement (Attachment C to Contract).
 - d. The Texas Family Code, as may be amended from time to time.
6. Payment under this contract will be made as follows: The County shall purchase **psychological and/or psychiatric evaluations, drug and/or alcohol testing, substance abuse treatment and/or counseling services** for youth referred to the juvenile probation department, during the grant period beginning September 1, 2013, and ending on August 31, 2014. Funds to be reimbursed to each county shall be subject to the Special Limitations listed on Attachment A of this Contract. Total reimbursements to all participating Counties shall not exceed the total amount available in the current grant (**\$55,000.00**). The County shall submit to ETCOG the Purchase Voucher with original signature (Attachment B to Contract), a copy of the bill for services purchased, and the Certification form with original signature (Attachment C to Contract) when making a request for reimbursement. Reimbursement will normally be made to County within 30 days of receipt by ETCOG.
7. **If the County has not exhausted its regional evaluation services allocation on or before July 1, 2014, said County shall notify ETCOG that it may be unable to use its allocated grant funds under this contract, so that ETCOG may plan for the possibility of redistribution. If the County has not exhausted its budgeted funds on or before July**

31, 2014, said County shall notify ETCOG of that fact, and shall release its unused grant funds for redistribution no later than August 25, 2014. Final requests for reimbursement from all Counties shall be provided to ETCOG no later than September 09, 2014. The final report for this grant is due to CJD by September 16, 2014. ETCOG shall complete the report, using data from all Counties which have participated in the grant project.

8. In the event of a default by the County, ETCOG may cancel or suspend the contract. In the event of a cancellation or suspension, the County shall be entitled to recover for all services properly provided prior to the cancellation date.
9. All licenses, legal certifications, or inspections required for the services, facilities, equipment, or materials, and all applicable state and federal laws and local ordinances must be complied with by the County. Failure to comply with this requirement shall be treated as a default.
10. This contract shall automatically terminate on the grant expiration date (**August 31, 2014**) or any extension date thereof granted by CJD, or upon the termination of the underlying grant by CJD. **All services billed hereunder must be rendered within the grant period. ETCOG shall not reimburse for any services billed under the grant unless the County bills such services to ETCOG within 10 days following the grant expiration date (August 31, 2014); i.e., by September 09, 2014.**
11. The County agrees and understands that the choice of the counselor, selection of personnel, and treatment of individual juveniles is solely the responsibility of the County, and ETCOG shall have no liability or responsibility for conditions of treatment of individual juvenile offenders.
12. The County agrees that psychological and/or psychiatric evaluation services shall be paid on a reimbursement basis, and claims for reimbursement shall reflect the actual costs of services. No increment above the cost or profit shall be paid under this agreement. It is further agreed and understood that **cost reimbursement for actual costs shall not exceed the maximum amount established by the State.**
13. The County shall be solely responsible and liable for any and all loss or damages to persons, property, or the environment, including damages to ETCOG, and including reasonable attorney fees and court costs occasioned by the County's performance under this contract. The County agrees to indemnify, to the extent permitted by law, and hold harmless ETCOG, its officers, directors, or employees against any and all claims arising out of or in any way related to psychological and/or psychiatric services, or to the expenditure by the County or its subcontractor of funds under this contract. More specifically, County shall indemnify and hold harmless ETCOG and its officers, agents and employees from all suits, actions, losses, damages, claims or liability of any character, type, or description, whether based on constitutional, statutory, or common law, including, without limiting the generality of the foregoing, all expenses of litigation, court costs, and attorney fees for injury or death to any person, or injury to any property, received or sustained by any person or persons or property arising out of or occasioned by the acts of the County or its agents, contractors, subcontractors, or employees in the performance of this contract. During each year while there is any liability by reason of this agreement, the County shall compute and ascertain the rate amount of tax which will be sufficient to raise and produce the money

required to pay any sums which may be or become due during any such year, in no instance to be less than two percent (2%) of such obligation, together with all interest thereon, because of the obligation herein assumed. Said rate and amount of taxes to be levied for each year while any liability exists by reason of the obligation undertaken by this agreement, and said tax shall be assessed and collected each year until all of the obligations herein incurred shall have been discharged and all liability hereunder discharged.

EXECUTED this 24 day of February.

David L. Adams
Signature of County Judge

Signature of Authorized Official
For ETCOG

Panola
Name of County

East Texas Council of Governments
Name of Grantee Agency

110 S. Sycamore St. Rm 216A
Address (street or post office box)

3800 Stone Road
Address (street or post office box)

Carthage TX 75633 ██████████
City State Zip Telephone #

Kilgore, TX 75662 (903) 218-6400
City State Zip Telephone #

- I. Reimbursement will be made only for Psychological or Psychiatric Evaluation services, Substance Abuse Testing &/or Counseling for youths referred to juvenile probation departments within the ETCOG region. Only one (1) of each of the above per youth can be funded through this grant.
- II. **Grant funds provided through this program may not be used to supplant funding previously allocated through the County's budget or any other State or Federal Grant specifically designated for any of the above services for youth.**
- III. Reimbursement for each county will be limited to the amount specified below, plus any funds which might be forfeited and redistributed as a result of a county or counties not returning an executed contract to ETCOG, or as a result of a county or counties de-obligating unused funds.

County **Allocation**

Anderson	\$6,500
Camp	\$2,000
Cherokee	\$3,000
Gregg	\$7,700
Harrison	\$4,300
Henderson	\$4,500
Marion	\$2,000
Panola	\$2,000
Rains	\$2,000
Rusk	\$4,500
Smith	\$8,000
Upshur	\$2,000
Van Zandt	\$4,500
Wood	\$2,000
<i>Total</i>	\$55,000

REIMBURSEMENT VOUCHER

Public Safety Director
 East Texas Council of Governments
 3800 Stone Road
 Kilgore, Texas 75662

Payable to: (County/Address)

Mail Payment to. (Name, Title)

Date(s) of Service	Gender (M/F)	Ethnicity/ Non-English speaking? (i.e. W/N)	Age	In School Y/N	School Type Public, AEP or Private	Child's grade level 9-12, 6-8, or 5th & under	Below Fed Poverty Level? (Y/N)	Mental &/or Physical Disability? (M/P/Both)	Testing Cost(s) each	Total \$ Amount

*** Note: Attach copy of invoice(s) for Evaluations/Testing/Counseling purchased. ***

I certify that the above services were rendered / received, that they correspond in every way with the contract under which they were procured, and that the invoice is accurate.

VOUCHER TOTAL	\$
Signature – Agency Representative	Telephone #
Title:	Date:

ETCOG Approval	Date Approved for Payment	ETCOG DISTRIBUTION ACCOUNT – FS #	AMOUNT

Signature:

Title:

Total Amount Requested to Date

Vendor Number	Coded. By	Check Number	Date:	Amount:

VOL. 87 PAGE 522

QT TECHNOLOGIES

4909 Nautilus Court North, Suite 109, Boulder, CO 80301
 Phone: (303) 444-3590 Fax (303) 444-8736
 e-mail: mduncan@qttechnologies.com

Extended Warranty and Service Policy Program

Site Name: Panola County Airport (M3000)	PO Number:
Address: 1305 Highway 79 North	
City: Carthage	State/Province: TX
Site ID: 1388	Postal Code: 75633
<input checked="" type="checkbox"/> Aviation <input type="checkbox"/> Marina <input type="checkbox"/> Other	
Model: M3000Plus	Serial Number: 3000405
Date Installed: 7/12/2005	

Policy Type:

Part ID	Description	Qty	List
GOLD	Gold Service Agreement	1	\$995.00

Coverage Included:

<input type="checkbox"/> Business Hours Telephone Support	<input checked="" type="checkbox"/> Free Software Updates
<input checked="" type="checkbox"/> 24/7 Telephone Support	<input type="checkbox"/> On-Site Technician for Repairs
<input type="checkbox"/> 25% Discount on Parts	<input checked="" type="checkbox"/> Prepaid Ground Freight
<input checked="" type="checkbox"/> 40% Discount on Parts	<input type="checkbox"/> Lightning Protection
<input type="checkbox"/> 100% Discount on Parts	

We Accept VISA and MasterCard payments or you may overnight a check or money order.

All service plans from QT Technologies are written contracts between QT Technologies and its customers. This letter is meant to provide a general description of the various plans to be offered. Please refer to the full text of the support contract you select for all inclusions and any exclusions or limitations.

QT TECHNOLOGIES *Features Description*

VOL. 87 PAGE 523

Business Hours Support - QT Technonolgies will provide telephone technical support on Monday through Friday from 7.30 AM to 6:00 PM MST, holidays excluded.

24/7 Support - QT Technologies provides support after-hours and on holidays to customers with GOLD and PLATINUM Service Plans. QT Technologies staff will respond to all calls within an hour of the initial call for service. After hours support is intended for emergency situations where you are unable to pump fuel

Software Upgrades - QT Technologies will provide GOLD and PLATINUM customers with software updates and revisions at no charge as they become available (a \$495.00 value). SILVER customers will be charged with the full retail price for software upgrades and revisions.

Parts Replacement - QT Technologies parts replacement policy is as follows: SILVER - Customers receive a 25% discount on all parts required to return unit to service. Customer is responsible for installation of parts and pays for both outbound and inbound shipping charges. GOLD - Customers receive a 40% discount on all parts required to return unit to service. QT Technologies will pay outbound shipping charges via UPS Ground Service. Customer may be responsible for overnight shipping charges should this method be requested. Customer is responsible for installation of parts and the inbound shipping charges. PLATINUM - Customer will recieve on a "parts exchange" basis at no charge. Customer is responsible for installing the new parts and must return the "old" parts within 10 days or is charged the full retail price. Parts replacement will be sent via UPS Ground Service at no charge. Customer may be responsible for overnight shipping charges should this method be requested.

On site Technical Assistance / On Site Repairs - The customer shall be responsible for installing all replacement components and shall return all failed components to QT. Should QT be unable to diagnose and/or repair the terminal within a reasonable time frame, QT will, at its sole descretion, dispatch a technician of its choosing to the Site for those customers covered under the PLATINUM plan. Customer shall not be responsible for labor charges. Customer shall bear the cost of travel expenses. The customer is responsible for any electrical repairs outside the unit caused by electrical failure, lightning, or other power surges. (Note: this service is not available in all areas. Check with your QT Technologies sales representative for details.)

Lightning Protection - QT Technologies offers PLATINUM PLUS customers a complete hardware replacement if the unit's failure is deemed to be the result of lightning or extreme power surges provided the customer's terminals equipped with a Sandwich Block (SB41) lightning suppressor and Data Line Protector (DLP-200).

Terms of Agreement

As an authorized agent of the above named company, and on behalf of the company, I agree to all the terms and conditions listed on this agreement and further agree to pay the amount specified either in whole or as specified herein. This agreement is 12 months in length and begins on the date QT receives payment and remains in effect for twelve continuous months. This contract is non-cancellable and non-refundable. QT Technologies agrees to honor this agreement as written only to the extent as specified in the Terms of Service as listed above. QT Technologies is not responsible for any damage to the covered unit or attached equipment resulting from the improper installations of parts by unauthorized technicians. Failure to pay the contract in its entirety will result in collections and legal actions by QT Technologies.

Agreed upon this day 1/30/2014 . Between QT Technologies and Panola County Airport (M3000)

QT Technologies Representative

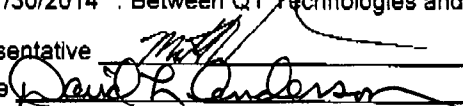

Date 1/30/14

Company Representative

Date 2-24-14